



# ELECTRICAL COMMUNICATION

ADVANCE DEVELOPMENT DEPARTMENT.

OCTOBER

No. 2

1933

VOL. 12

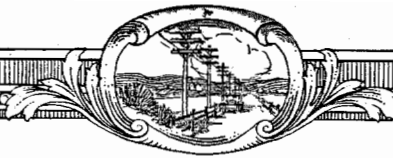

# ELECTRICAL COMMUNICATION

A Journal of Progress in the  
Telephone, Telegraph and Radio Art

H. T. KOHLHAAS, Editor

EDITORIAL BOARD

E. A. Brofos    P. K. Condict    G. Deakin    E. M. Deloraine    P. E. Erikson    John W. Foard  
James E. Fullam    F. Gill    Frank C. Page    H. M. Pease    G. E. Pingree

Published Quarterly by the

## *International Standard Electric Corporation*

Head Offices

67 BROAD STREET, NEW YORK, N. Y., U. S. A.

European General Offices

CONNAUGHT HOUSE, ALDWYCH, LONDON, W. C. 2, ENGLAND

G. E. Pingree, President

S. G. Ordway, Secretary

Joseph A. Redegeld, Treasurer

Subscription, \$3.00 per year; single copies 75 cents

Volume XII

OCTOBER, 1933

Number 2

### CONTENTS

	PAGE
THE 7-D AUTOMATIC TELEPHONE SYSTEM IN THE HAARLEM RURAL AREA . . . . .	63
<i>By F. O. Bloembergen, E.I.</i>	
THE NEW ITALY-SARDINIA TELEPHONE CIRCUIT . . . . .	76
<i>By Prof. Ammiraglio Giuseppe Pession</i>	
A NEW 120 kW VACUUM TUBE . . . . .	86
<i>By W. T. Gibson, M.A., O.B.E. and G. Rabuteau</i>	
THE SINGLE SIDE-BAND SYSTEM APPLIED TO SHORT-WAVE TELEPHONE LINKS . . . . .	90
<i>By A. H. Reeves</i>	
THE CONDENSER CONE . . . . .	92
<i>By J. K. Webb, M.Sc., A.M.I.E.E.</i>	
RADIO BROADCAST RECEIVERS . . . . .	104
<i>By J. S. Jammer and L. M. Clement</i>	
THE VARIATION OF OVERALL ATTENUATION WITH CURRENT STRENGTH IN A TELEPHONE CIRCUIT LOADED WITH COILS HAVING NON-LINEAR CHARACTERISTICS . . . . .	117
<i>By K. E. Latimer, B.Sc.</i>	
THE RURAL TELEPHONE SITUATION IN HUNGARY . . . . .	124
<i>By S. Ledeczy</i>	
THE 7-A.2 ROTARY AUTOMATIC TELEPHONE SYSTEM, PART III . . . . .	128
<i>By L. Schreiber and W. Hatton</i>	



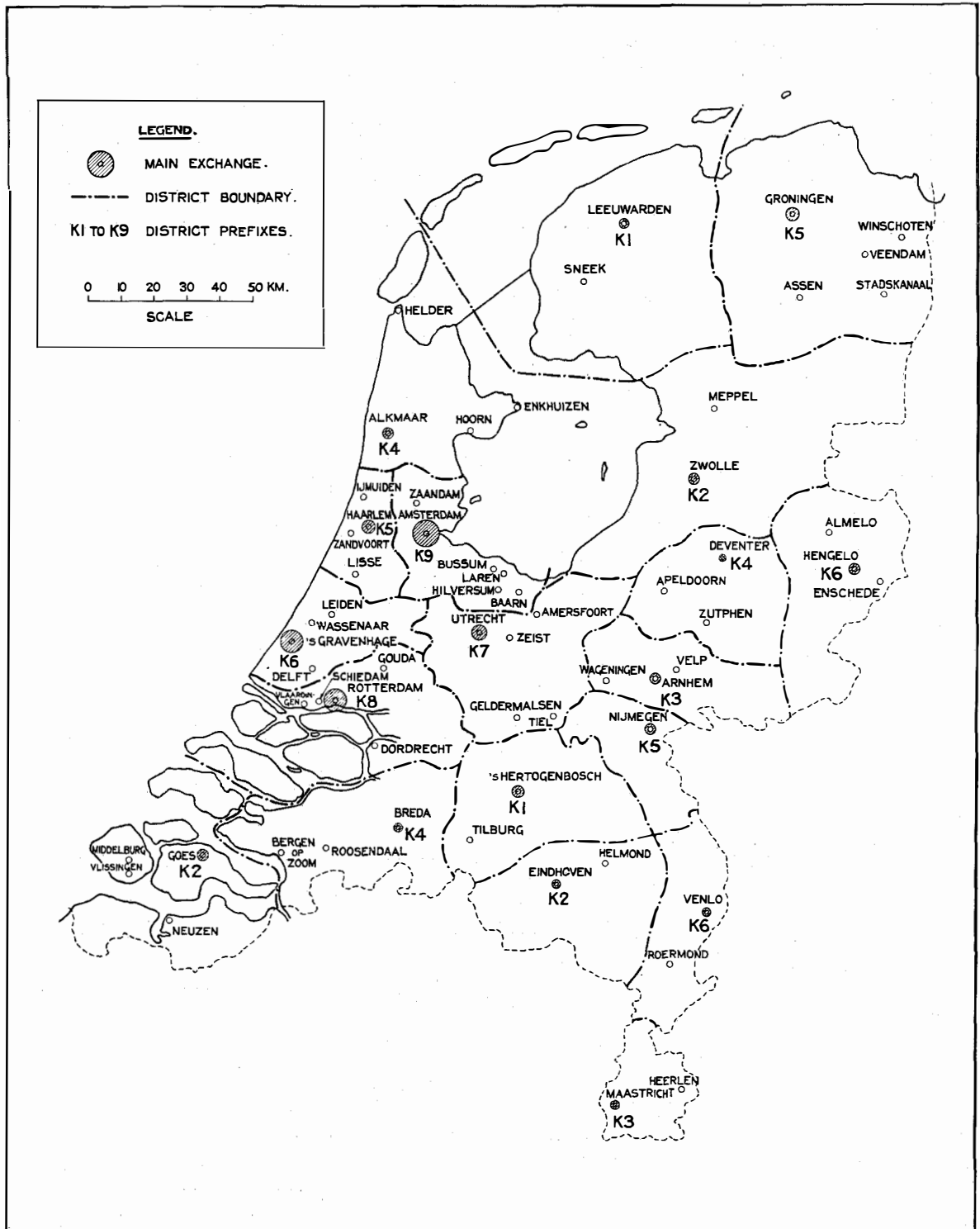

Map of Holland Divided into Nineteen Zones.

# The 7-D Automatic Telephone System in the Haarlem Rural Area

By F. O. BLOEMBERGEN, E.I.

*Engineer of the Dutch Telegraph Administration*

## General

**T**HE introduction of automatic telephony in the Haarlem rural zone forms part of the project to convert the Dutch Telephone System into automatic working. The Haarlem rural zone is one of nineteen into which the country is divided.

Each rural zone embraces a number of centre exchanges grouped around a pivotal point, the so-called main exchange. From the main exchange, junctions radiate to these centre exchanges which in turn form the pivotal points of so-called sectors. A sector furthermore contains some exchanges of less importance, connected directly to the centre exchange. Dependent upon the number of subscribers and the extent of their traffic, these smaller exchanges are called sub-centre or district exchanges.

Full automatic operation is provided throughout the zone. All traffic leaving a sector is routed via its controlling point, i.e., the centre exchange. The traffic from sector to sector is routed via the main exchange which also handles the traffic between the zones. Figure 1 shows a theoretical rural zone.

Small exchanges situated in the neighbourhood or sector of the main exchange are connected to the so-called centre-in-main exchange. This centre-in-main exchange is a centre exchange without local subscribers and is located in the main exchange building.

The city exchange or exchanges, i.e., the local exchanges of the town where the main exchange is situated, are also connected directly to the main exchange.

The toll traffic which is dealt with on a manual basis, is concentrated in the main exchange. Here a toll board takes care of all traffic originating in the rural zone which cannot be established on an automatic basis, for instance, the traffic to and from exchanges which

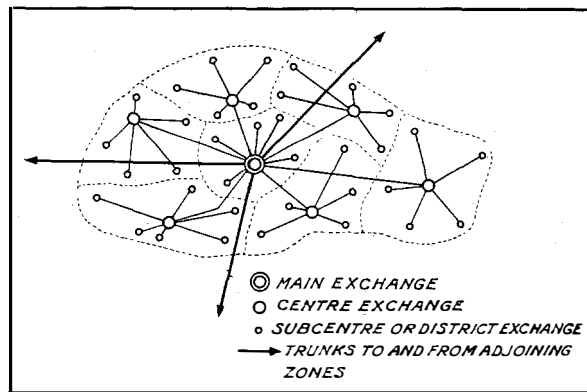

Figure 1—Theoretical Rural Zone.

have not yet been converted to automatic operation.

As the automatic inter-zone traffic for the present is limited to adjoining zones, all traffic to and from other zones is also completed via the toll board.

A toll operator can automatically ring up any rural subscriber in the zone and establish a connection between his line and a toll line.

A consistent numbering scheme is used for all rural zones throughout the country. To each exchange a special prefix is allotted consisting of the letter K (equivalent to the figure 0) followed by three digits. The first digit indicates the zone, the second the sector in the zone and the third the specific exchange in the sector.

For local calls a subscriber omits the prefix altogether and only dials the numerical designation immediately he hears the dialling tone. For all other calls whether to subscribers of the same zone or of an adjacent zone, he first dials the prefix, awaits a second dialling tone and thereupon sends the numerical designation.

The Frontispiece shows a map of the country divided into nineteen zones. In each zone the first figure of the prefix is indicated, which characterizes its accessibility from other zones.

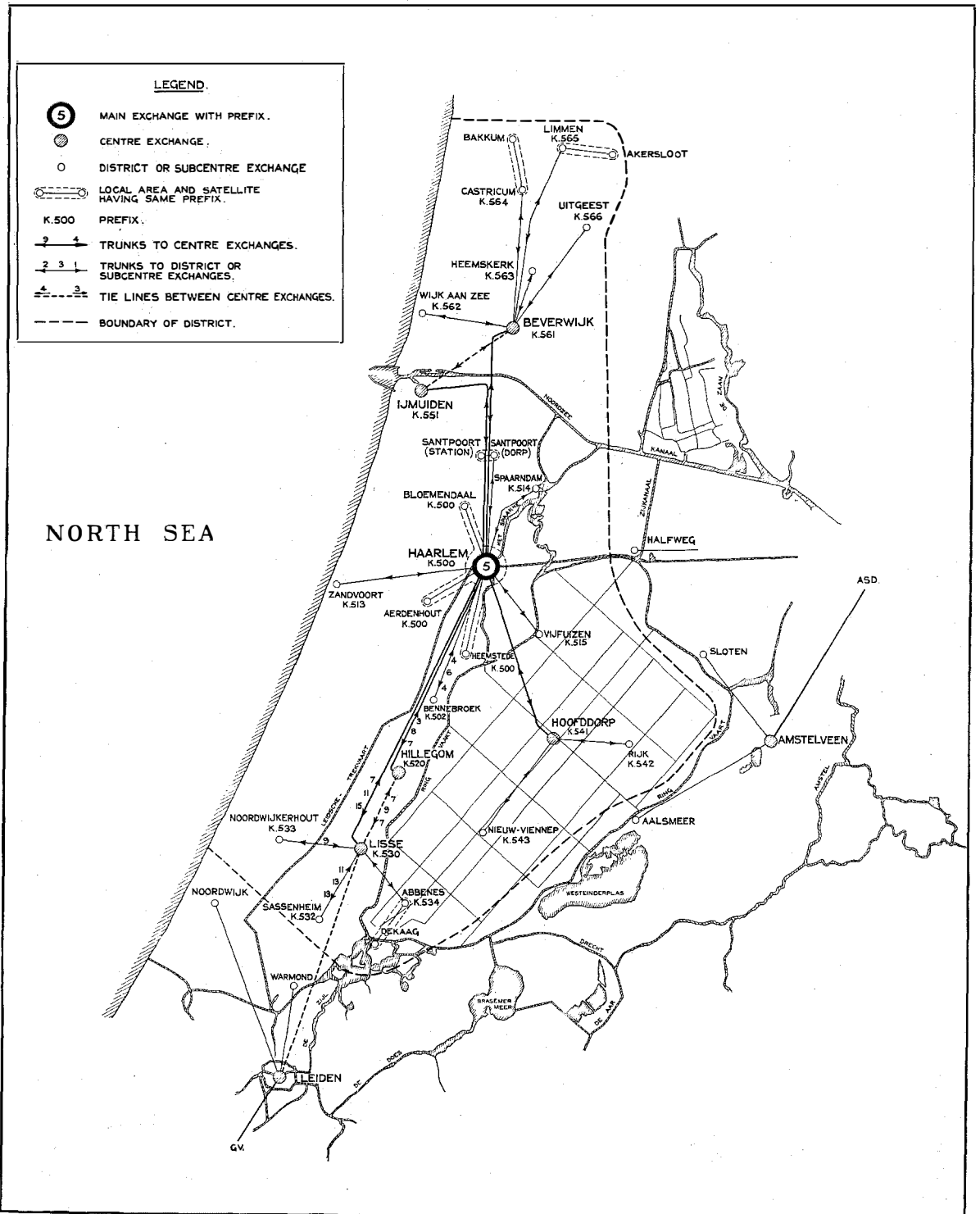

Figure 2—Haarlem Rural Zone.

It will be clear that besides the local district, eight other zones may ultimately be reached entirely by automatic means, "K0" being reserved for special services.

Figure 2 shows a map of the Haarlem rural zone and the exchanges it contains. Each exchange bears a prefix which begins with a 5, this being the figure allotted to this zone.

Table I contains the names of the exchanges already working and of those under construction, with some particulars of interest.

The southern part of the Haarlem rural area is famous for its bulb growing nurseries and is therefore called the "Bulb Area." Lisse and Hillegom are the centres of the bulb trade. Both towns have centre type exchanges. The Sassenheim and Noordwijkerhout exchanges are connected to the Lisse exchange. As the traffic between the Lisse and Hillegom sectors is important in both directions, this traffic is routed via direct tie lines. Bennebroek is connected to the centre-in-main exchange at Haarlem and traffic between Bennebroek and the other rural exchanges passes via Haarlem main exchange. All traffic originating in the zone and destined for subscribers of the Haarlem city exchange and sub-exchanges is also completed automatically. Calls from subscribers belonging to the Haarlem local area destined for rural subscribers, however, are for the time being dealt with on a manual basis as the existing 7-A exchanges do not permit "dialling out".

It is interesting to point out that the type of equipment used for sub-centre exchanges in the Haarlem zone is actually of the centre type. These sub-centre exchanges have such a large amount of local traffic that the use of registers is

justified and they therefore do not differ from centre exchanges as far as their layout of automatic equipment is concerned.

View of the equipment and exchanges are shown in Figures 3, 4, 7, 8, 9, 10 and 11. Figure 5 shows a routing diagram and Figure 6 a group and level numbering diagram.

In the following paragraphs a brief description is given of the various kinds of calls and the manner in which they are routed.

### *Calls from a Centre or Sub-Centre Exchange Subscriber*

#### *(a) Local Calls.*

When a subscriber wishes to originate a local call, he lifts his receiver and his line is seized by one of a group of first line finders associated with the 100 subscribers' line block to which his line belongs. A group of second line finders hunts for the engaged first line finder and when this is found, the link finder of a free register seizes the successful second line finder circuit, thereby connecting the line to a free register from which dialling tone (150 cycles per second) is conveyed to the calling subscriber.

The subscriber now dials the local number of the wanted party. The digits which are dialled are stored in the register on marker switches. As soon as the first digit is received the setting of the first group finder commences. The first group finder control circuit allotted to the group of first group finders to which the engaged first group finder belongs is now connected via the fundamental circuit to the register. First the control circuit hunts for this first group finder and having seized it, it starts the register. The

TABLE I

Name	Prefix	Type of Exchange	System	Equipment Installed	Status
Haarlem.....	K500	City exchange	7-A	7600	In service
Bloemendaal.....	K500	Sub-exchange of Haarlem	7-A	1800	In service
Aerdenhout.....	K500	Sub-exchange of Haarlem	7-A	960	In service
Heemstede.....	K500	Sub-exchange of Haarlem	7-A	1600	In service
Bennebroek.....	K502	Sub-centre exchange	7-D	300	Cutover end of 1933
Hillegom.....	K520	Centre exchange	7-D	800	Cutover end of 1933
Lisse.....	K530	Centre exchange	7-D	600	Cutover Sept., 1933
Sassenheim.....	K532	Sub-centre exchange	7-D	600	Cutover Sept., 1933
Noordwijkerhout.....	K533	District exchange	7-D	150	Cutover Sept., 1933
Ymuiden.....	K550	Centre exchange	7-D	1800	Cutover in 1934



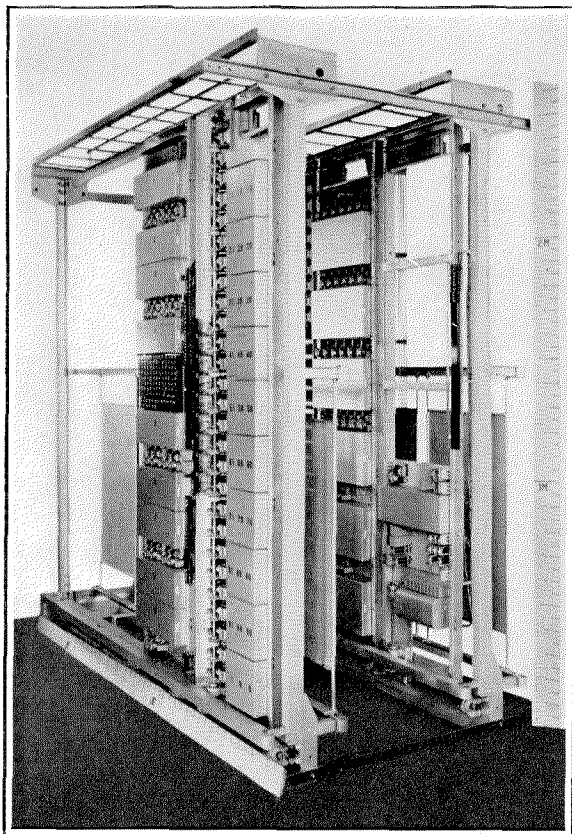

Figure 3—Switchrack equipped with Finder and Final Bays and Combined Bays Mounting Associated Circuit Apparatus, also Message Registers, Line and Cutoff Relays, Junctions, Control Circuits and Miscellaneous Apparatus. (Horizontal and Vertical Dimensions in Metres.)

register now sends out a number of impulses by means of an impulse switch, which forms part of the fundamental circuit. As no translation is necessary the same number of impulses is sent out as has been received by the register. As soon as the control circuit is set the first group finder is started and hunts for a free second group finder—assuming that a four figure number is dialled—belonging to the group which is marked by the control circuit. The first group finder tests through the second group finder on a second group finder control circuit, which now hunts for the engaged second group finder and as soon as the control circuit is ready to receive the impulses, it causes the register to start again. After the second digit has been received the fundamental circuit is closed once more and the second group finder control circuit is set accordingly. The second group finder now hunts for a

free final finder in the known manner. The final finder is set under the control of a final finder control circuit which marks both the tens and units sent out from the register. As soon as the final finder is set on the wanted subscriber's line, it tests whether the line is busy or free. If the wanted subscriber's line is free, ringing current is sent out on his line, whereas the calling subscriber receives a ringing tone. As soon as the called subscriber removes his receiver, the metering apparatus in the link circuit commences to function and the subscriber's message register is operated immediately. The calling subscriber is metered once regardless of time.

Should the called party be busy, the calling subscriber receives a busy tone (450 cycles per

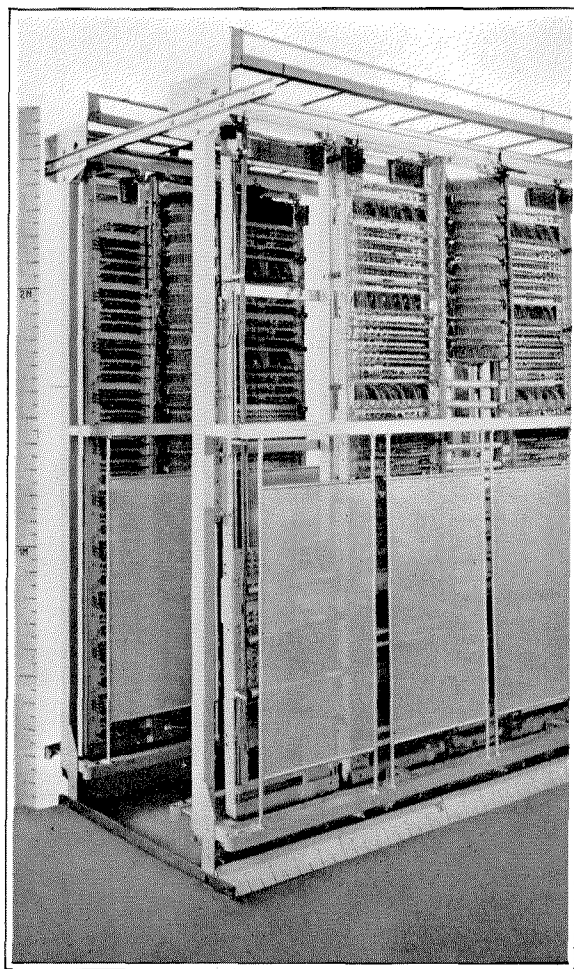

Figure 4—Rear View of Switchrack and Bays shown in Figure 3, with Protective Shields particularly in evidence. (Horizontal and Vertical Dimensions in Metres.)

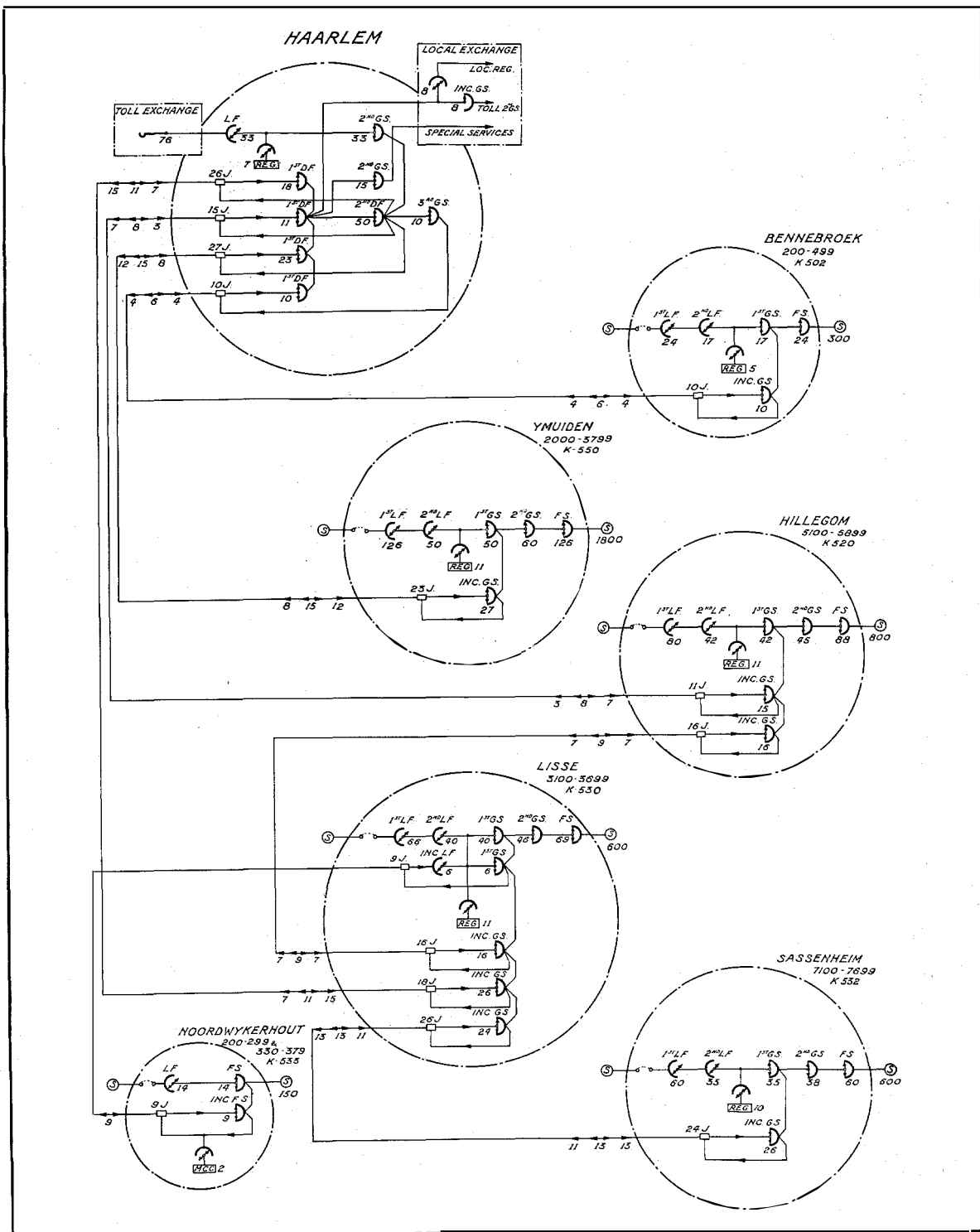

Figure 5—Routing Diagram.



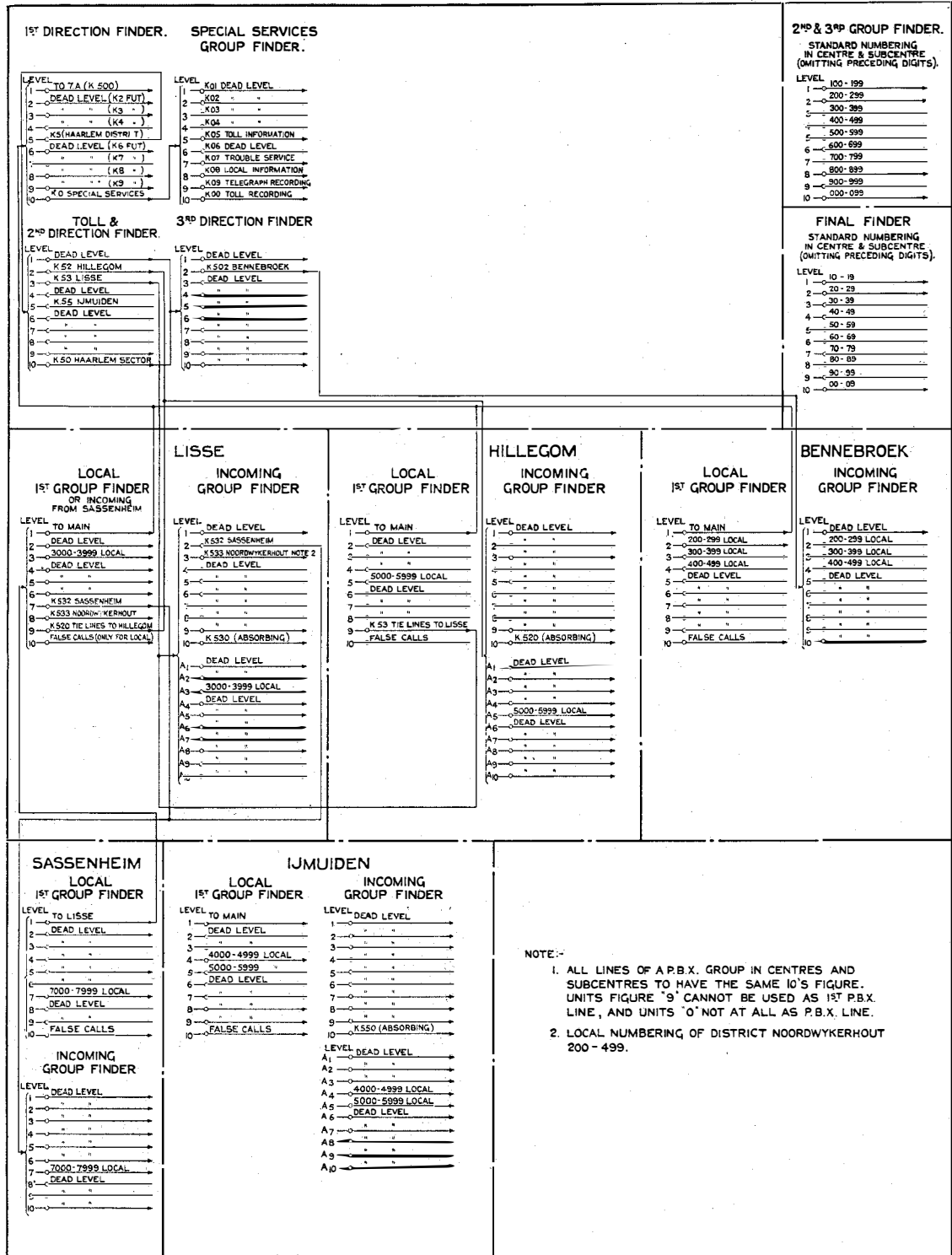

Figure 6—Group and Level Numbering Diagram.

second interrupted) and restores his receiver. The circuits engaged are then released.

In the event of a calling subscriber holding a connection for an excessive length of time after the called subscriber has restored his receiver, indication thereof is given at the exchange by an alarm and a lamp signal. The circuits are, moreover, arranged for delayed back release so that after the expiration of a certain time the called subscriber's line is released even if the calling party does not release the connection.

*(b) Calls to Subscribers of Another Rural Exchange in the Same Zone.*

In case a subscriber desires to call a party whose line is connected to another exchange in the same zone, he dials K followed by the prefix of the exchange in question.

As an example, the case of a Sassenheim subscriber wishing to call a Bennebroek subscriber is assumed. The Sassenheim subscriber lifts his receiver and is connected in the well known manner to a free register. Upon hearing the dialling tone he dials K502, this being the prefix allotted to Bennebroek. These four digits are stored on marker switches. For the present no other zones can be reached, the first figure of the prefix being therefore either a 5 for subscribers or an 0 for special services. Only when the second figure is received, is the routing of the call determined. As the second figure is an 0 the call is routed via the main exchange. The fundamental circuit for the first group finder control circuit is now established. From Figure 6 it will be seen that the outgoing trunks to Lisse are connected to the first "level" (i.e., group of contacts). The register therefore has to make a translation as one impulse only is necessary. An incoming group finder at Lisse is now seized and as the outgoing trunks to Haarlem main are also connected to "level" 1 the register must make an artificial selection consisting of one impulse. For all calls, which are tandemed through Lisse, an artificial selection must be made.

After this second selection an incoming finder in main is seized—the so-called first direction finder which gives access to other zones besides the local zone. As, however, no other zones are connected for the present, all except the 1st,



Figure 7—Sassenheim Exchange Building.

5th and 10th levels are free. When this direction finder has received five impulses from the register, these impulses are stored on a marker switch, whereupon a second direction switch is engaged. The subsequent digit sent producing ten impulses is received by the marker switch of this second direction finder. The latter now hunts for a free third direction finder giving access to exchanges belonging to the sector Haarlem (K50). As soon as a free third direction finder is seized the register is again started, whereupon two impulses—equivalent to the last figure of the prefix—are sent out. The third direction finder is set on a trunk connected to "level" 2 and a free incoming group finder at Bennebroek is engaged. Translation has only taken place for the setting of the local first group finder at Sassenheim and the incoming group finder at Lisse. K502 has been sent in and 1-1-5-10-2 sent out.

Meanwhile still another switch in the register

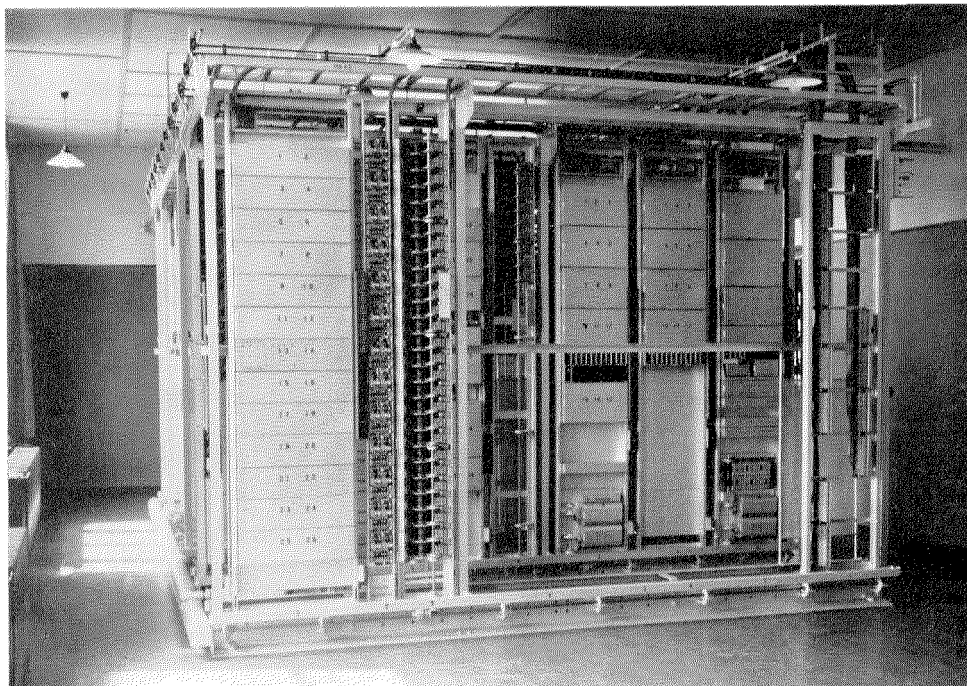

*Figure 8—Sassenheim Exchange—Interior View.*

has been set, namely, the “translator”. This translator, consisting of a normal 100 point switch with seven brushes, can be set in a position which is peculiar to each prefix dialled. In this position the translator not only indicates the nature of the call but also the metering zone. In the present case, for example, the translator has indicated that the wanted exchange has subscriber’s numbers consisting of three digits. This is important, as the register is normally arranged to store four digit numbers.

As soon as the connection is completed to the wanted exchange, the register is restored to normal but remains connected to the link circuit. This link circuit now sends out a second dialling tone (450 cycles per second); at the same time, the metering zone is determined in the link circuit by a combination of relays. The calling subscriber now proceeds to dial the local number, the register stores the three digits dialled and takes care of the selection of the wanted

line. When the whole connection is completed the register is released, whereas the called subscriber, if free, is rung automatically in the normal way. As soon as the called subscriber removes his receiver, metering starts. The calling subscriber is metered at the beginning of each three-minute period with a maximum of six minutes, after which the connection is forcibly released.

As the metering of the various zones is based on a multiple of the local unit of  $2\frac{1}{2}$  cents, the message register is energised as many times as the conversation tariff can be divided by  $2\frac{1}{2}$ .

From Figures 5 and 6 it may be seen how other rural calls are established. Calls between subscribers belonging to two different exchanges in the same sector do not pass via the Haarlem main exchange but are routed via the centre exchange of the sector.

The incoming group finders of Hillegom and Lisse are so-called “absorbing” group finders.

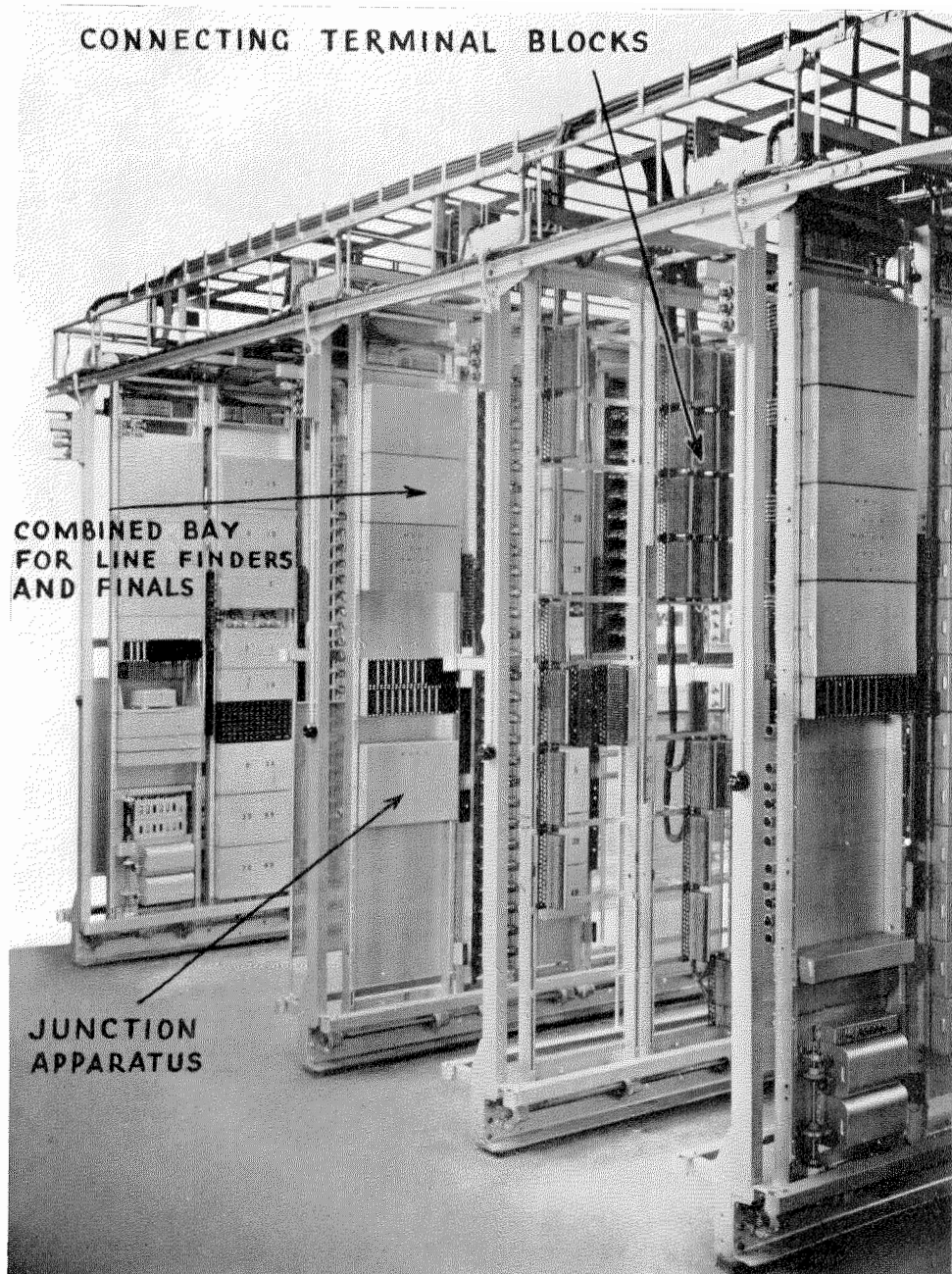

*Figure 9—General View of a Number of Switchracks for Lisse Exchange, Mounting Line Finder and Final Bays and Combined Bays with Associated Circuit Apparatus, showing also Terminal Racks and Junction Bays.*

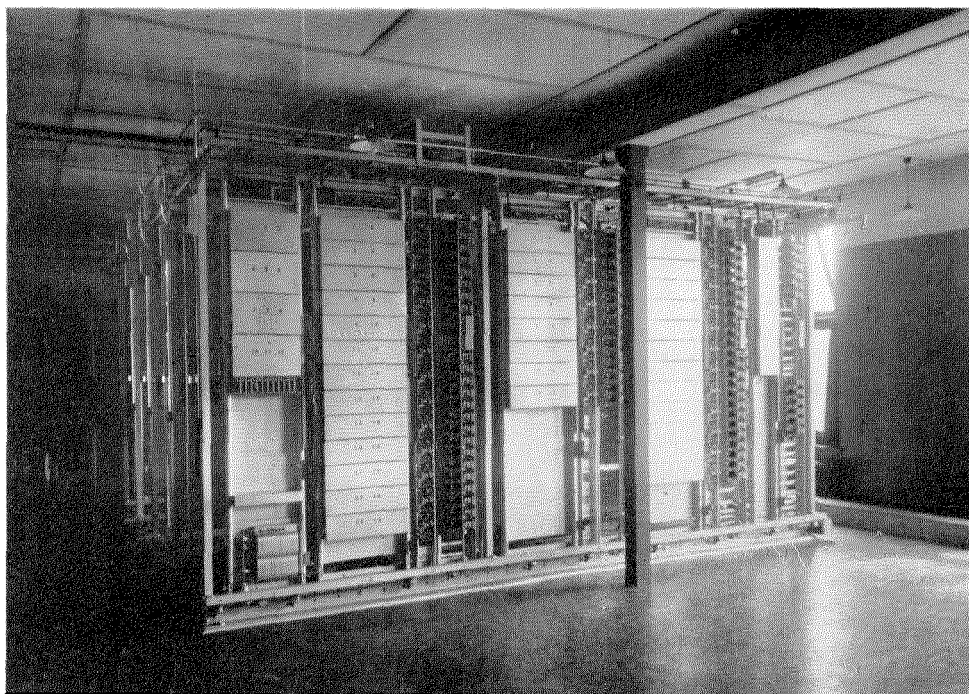

*Figure 10—Lisse Exchange—Interior View.*

These group finders give access to both local and outgoing levels. As long as the aggregate number of local and outgoing levels does not exceed ten, the incoming group finder may be used for both purposes.

If the last figure of the prefix denotes the exchange itself, the setting of the group finder is delayed until the first figure of the subscriber's number is received. One selection is therefore "absorbed"; hence the name.

*(c) Calls to Subscribers of the Haarlem City Area.*

To establish a call to one of the Haarlem city exchanges, a rural subscriber dials K500. The routing of the call is as already described. In this case the first direction finder in main is set to "level" No. 1, this being the "level" to which the rural cord circuits are connected. As the subscribers' numbers consist of five digits, they cannot be received on the four marker switches of the local register. The register therefore

releases and after having prepared the metering as required, the second line finder takes up the metallic through-position enabling the outgoing trunk circuit to provide the transmitter current by means of a repeating coil bridge. In the main exchange a rural cord circuit is seized, a local register suitably altered for the purpose is attached and a second dialling tone is given.

Upon hearing this second dialling tone, which only in this or identical cases, is given from a distant exchange, the subscriber dials the wanted five-digit number, which is stored in the register. The call is now completed via the toll train of switches, already existing, but modified to meet the new conditions, which is necessary as such rural calls are considered equivalent to toll calls and may not be broken down by a toll operator. In case the wanted subscriber is busy, a busy tone is given by the second group selector; if he is free, automatic ringing is sent out.



The same method of operation can also be used when automatic interworking with step-by-step areas becomes necessary. In that case the local register receives the prefix and retransmits it, after which the register is liberated. The special arrangements in the outgoing trunk circuit, as described above, make it possible to dial through directly into the step-by-step area. Since the last two digits of the prefix must also be received in the step-by-step area, the main register is arranged to forward the correct dial type impulsing before these selections are made.

(d) *Calls to Special Services.*

Calls to special services are established by dialling K0 followed by a third figure. The routing may be seen in Figure 5. The first direction finder in main is set to "level" 10, a second group finder for special services is seized and directed by the local register to the wanted level.

The following special services are provided:

- K00 Toll recording.
- K09 Telegraph recording.
- K08 Local information.
- K07 Trouble service.
- K05 Toll information.
- K04 Administration.

### *Calls from a District Exchange Subscriber*

(a) *Local Calls.*

When a Noordwijkerhout subscriber wishes to establish a call he lifts his receiver, whereupon his line is seized by a local link circuit and automatically connected through to an incoming link circuit at Lisse. At Lisse a local register is seized which sends back the dialling tone; meanwhile at Noordwijkerhout a so-called metering control circuit is attached to the outgoing trunk circuit.

Upon hearing the dialling tone the subscriber begins to dial and the first digit is received both in the metering control circuit and in the register at Lisse. As the first figure is not a K, the metering control circuit releases the junction to Lisse and gives indication to the local link circuit which figure has been dialled.

As the maximum capacity of this type of exchange is 300 lines the subscribers are divided into three groups of 100 lines attached to link

circuits each having three final finders of which the brushes are connected in parallel. The first digit characterizes the group of 100 lines to which the wanted line belongs and the metering control circuit indicates which of the three final finders has to be set. The next two digits are received in the link on marker switches after which the final finder is set to the wanted line. Ringing current or busy tone is given in the normal way.

(b) *Outgoing Calls.*

For an outgoing call a prefix is dialled and as the first digit is K the register at Lisse takes care of the call. The prefix is also received by the metering control circuit which prepares the metering determined by the link circuit. In such cases the register at Lisse receives indication that the call is "incoming" and that the metering is taken care of at the distant originating exchange.

If all junctions to Lisse are busy the calling subscriber is connected to an "all trunks busy

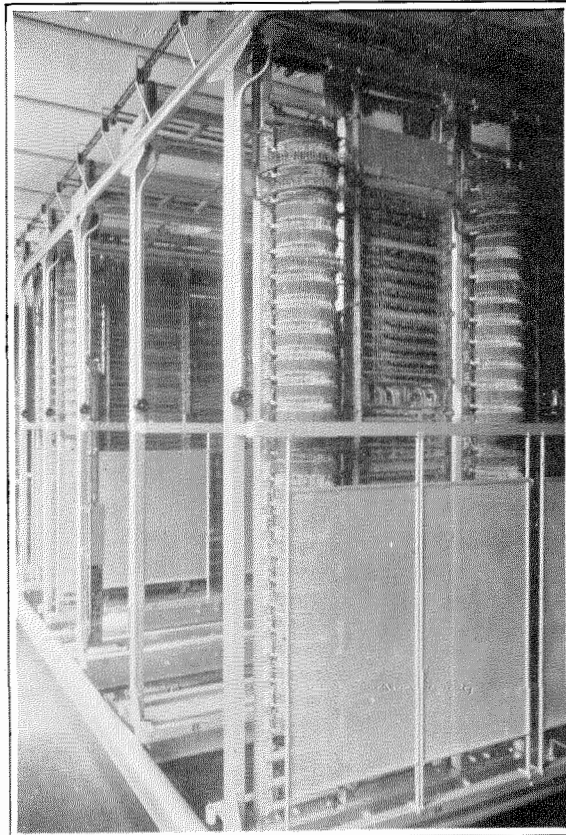

Figure 11—Lisse Exchange—Finder Bays—Rear View.



circuit" which sends back dialling tone. If the desired connection is with a local subscriber, it is established in the manner already described; the "all trunks busy circuit" indicating to the link circuit which was the first digit dialled. If, however, an outgoing call is wanted the caller receives a busy tone.

In case of a false call or permanent loop, a special permanent loop relay provided in the subscriber's line circuit is operated, whereupon the junction and link circuits are released.

(c) *Toll Calls.*

Toll calls are established by operators at the Haarlem toll exchange and are routed via the same incoming train of switches as are used for ordinary incoming calls. As for the present it is only required that the Haarlem rural zone be reached in this way, the operator need not dial K5. She therefore only dials the last two figures of the prefix immediately followed by the subscriber's number. All digits are received in a special toll register which can store a maximum of six digits. This register takes care of the selection. If the wanted line is free, the called party is rung automatically. After conversation he may be re-rung by the operator. The beginning and end of the conversation are signalled in the normal way by a cord lamp. In case the wanted party is busy, whether on a local or a distant connection, the operator receives a busy tone. By throwing the ringing key of the cord circuit, she is able to enter in on the existing connection and offer the toll call. The length of time a final finder circuit may remain in the offering position is limited to the time required for offering the call, this in order not to cause an unnecessary waste of energy in case the operator when offering is not allowed by the subscriber to break down the connection.

None but a local call may be broken down in favour of a toll call and then only after the latter call has been offered and accepted. The operator breaks down by throwing the ringing key for the second time, provided that the time limit for offering has not expired.

Distant connections and toll calls cannot be broken down.

All existing toll positions in Haarlem are arranged for outgoing calls to rural subscribers.

Each two positions have four outgoing jack circuits which are connected to the arcs of the rural links. For connections between Haarlem subscribers and rural subscribers four positions have been arranged in such a manner as to enable dialling over both cords.

### *Special Features*

(a) *P.B.X. Hunting.*

All groups of final finders are arranged for P.B.X. hunting. The P.B.X. lines may be distributed over all final groups in order to obtain a uniform distribution of traffic.

(b) *Message Registers.*

Message registers are provided for all subscribers' lines. A local call is metered once regardless of its duration, as soon as the called party answers.

For outgoing calls metering takes place at the beginning of each three-minute period. Metering commences for the first time after a short lapse of time for which no charge is made and which has been introduced to give the caller the opportunity to release immediately in case of a wrong connection. The meter may be operated four, six, fourteen or twenty times for each three-minutes, depending upon the distance. Before the expiration of each such metering period, the subscriber receives a warning tone. After six minutes the call is broken down.

(c) *Alarms.*

Alarm signals are provided in each exchange for all well known failures which may occur. Moreover, these alarm signals may be transferred to the main exchange by a standard alarm transfer circuit over trunks especially assigned for the purpose. At the main exchange a lamp glows in this case, indicating the exchange where an alarm has occurred. By pushing a key an alarm identification circuit in the distant exchange is operated, so that the lamp commences and continues to flash in a certain code indicating the nature of the failure.

(d) *Metering Control.*

In order to determine at the various exchanges the total number of calls passing the local link circuits and also the total number of metering

impulses, two traffic meters are provided per local link circuit for all the centre and sub-centre exchanges and in the case of Noordwijkerhout an additional traffic meter per outgoing junction.

Two portable traffic metering boxes each equipped with ten meters are provided in order to observe the number of calls and impulses per zone.

*(e) Test Panels.*

Test panels are provided for each exchange. They are equipped with the ordinary equipment for testing of subscribers' lines, such as test lines to M.D.F., incoming lines from automatic dial equipment, etc.

*(f) Routine Testing Facilities.*

The equipment of the various exchanges is

arranged for manual routine testing. The testing is carried out by means of a test box which is connected to the circuit to be tested by means of plugs.

*(g) Insulation and Loop Resistance of Subscribers' Lines and Junctions.*

The system is designed to operate on subscribers' lines with a maximum loop resistance of 1000 ohms including the telephone set. For junctions the maximum permissible loop resistance is 1400 ohms.

Impulse correctors are introduced in all circuits over which instepping or outstepping is performed.

The minimum insulation resistance required is 10,000 ohms for subscribers' lines and 50,000 ohms for junctions, between two wires of a pair and between each wire and ground.

# The New Italy-Sardinia Telephone Circuit

By PROF. AMMIRAGLIO GIUSEPPE PESSION

*Direttore Generale Delle Poste, Telegrafi e Telefoni d'Italia*

THE island of Sardinia is sparsely populated and its economic development has until recently been neglected. This is not because there is any lack of natural resources, for there is a considerable area of only partially utilised land suitable for stock raising and agriculture; water power is available, there are several good harbours, and the climate, scenery and historical interest will, in time, attract tourists. The greatest single factor which has retarded development is lack of communications. Perhaps the most remarkable instance of the isolation of certain parts of the island is the existence of a local dialect bearing a closer resemblance to the original Latin than is to be found in the speech of the mainland.

Under the Fascist régime much has been done to improve communications. For example, both seaplane services and luxurious motor ship services are available between the island and the mainland.

Telephonic communication with the mainland was first established by means of a radio link in September, 1930, and the traffic soon became sufficient to justify the laying of a submarine telephone cable. Accordingly, in April, 1932, a cable was laid and in June it was opened to traffic in connection with the pilgrimages from all parts of the world to Sardinia on the occasion of the fiftieth anniversary of the death of Garibaldi.

This cable is 146 nautical miles in length and is thus considerably longer than any submarine telephone cable previously laid.

It is proposed in this article to discuss the reasons which led to the adoption of the particular cable design employed and also to give some details of the connecting lines and terminal equipment.

## *General Considerations of Design*

### *System Design.*

The requirements which decided the type of

transmission system to be employed on the Italy-Sardinia cable were the following:

- (1) Owing to mechanical considerations, only a single core gutta percha insulated cable could be considered.
- (2) It was necessary to provide for one telephone channel and two telegraph channels (only one of the latter was required immediately), the terminals in each case being at Rome and Sassari.
- (3) The telephone channel had to be of an inherently reliable type unaffected by speech level variations and suitable for use on long switched connections without special precautions being necessary.
- (4) Owing to the unavoidable presence of power lines, telegraph cables and other potential sources of interference in the vicinity of the cable landing points, transmission levels lower than minus 40 db. were deemed undesirable in the voice frequency range, while somewhat lower levels in the order of minus 60 db. might be considered in the carrier range. (It will be appreciated that before the cable was laid only a rough estimate of the noise could be made).
- (5) Inter-modulation effects between the various channels had to be kept within reasonable limits.
- (6) It was not convenient to establish a repeater station at either landing place, although a station not far from the coast was possible in Sardinia.
- (7) It was desirable that the equipment should line up as far as possible with normal repeater station apparatus.

The use of continuous loading was necessary to obtain the low attenuation laid down in requirement (4) on a cable of the type specified in requirement (1). A careful consideration of the remaining requirements leads naturally to the choice of a system in which the telephone channel is obtained as a normal voice frequency balanced two wire circuit, while one telegraph channel is composited and the other obtained by carrier operation. Owing to requirements (4) and (5) no economies could be effected in the cable design to compensate for the increased cost of the equipment by the use of V.O.D.A.S.,<sup>1</sup> Stabilised working<sup>2</sup> or Zweiband operation<sup>3</sup>. In

<sup>1</sup> Voice Operated Delayed Action Switching.

<sup>2</sup> *P. O. E. E. Journal*, Jan., 1933, p. 276.

<sup>3</sup> *T. F. T.*, Vol. 18 (1929), p. 312.

addition, each of these systems introduced extra complications, while the first two conflicted with requirement (3).

The choice of the two wire system did, however, introduce a new requirement, namely, that the singing point of the cable should exceed the loss over the working frequency range<sup>4</sup>.

In view of experience gained on the original Key West-Havana cables<sup>5</sup> and on the Gran Canaria-Tenerife cable<sup>6</sup>, it was felt that by taking certain precautions, it would be possible to obtain a singing point of about 40 db. on this cable, comparing with the figure of from 30 to 35 db. obtained on the original Key West-Havana cables.

It was, therefore, decided that a continuously loaded concentric return cable of the original Key West-Havana type, with an attenuation of about 37 db. at 2,500 cycles, would be satisfactory. This would allow a margin of 3 db. for equipment unbalances, loss of singing point due to repairs, etc.

The cable over the direct route, as previously stated, is about 146 n.m. in length, and it was found quite difficult to obtain the low attenuation required without making the cable too heavy. It would have been possible to avoid this difficulty by effecting an intermediate landing at the island of Monte Cristo and installing repeaters at this point, but the increase in total route length and the extra equipment involved rendered this plan uneconomic.

**Submarine Cable Design and Manufacture**

As the Western Electric Company had considerable experience in connection with the Key West-Havana cables, they acted as consulting engineers for the Societa Italiana Pirelli with regard to the design of the cable.

Although the manufacture and testing of the cable are being discussed in another paper, it is of interest to note here the mechanical particulars of the design finally adopted. The dimensions and weights of the components of the core are given in Table I.

In addition to the line core as described above,

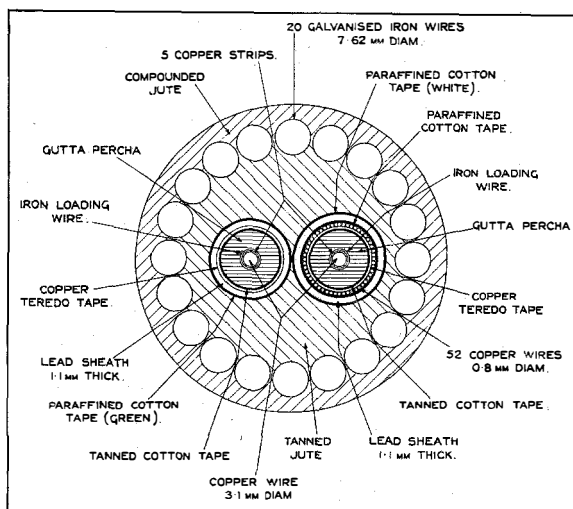

Figure 1—Cable Cross-Section, Type A2LC.

a second core without a return conductor is provided as a sea earth at each shore end and con-

TABLE I

Description	Dimensions in Millimetres	Weight in lbs. Per n.m.
<b>CENTRAL CONDUCTOR</b>		
Round copper wire, diameter 3.1	1.96 x 0.32	370
5 copper strip surrounds....		
<b>LOADING</b>		
1 layer iron wire, diameter.. 0.25	—	80
Compound.....	—	—
<b>GUTTA MIXTURE</b>		
(55% pure gutta)		
3 layers to diameter of..... 12.1	—	409
Tanned cotton tape..... 0.1 x 25	—	164
Copper teredo tape.....	—	—
<b>RETURN CONDUCTOR</b>		
52 round copper wires, diameter..... 0.8	—	980
Paraffin impregnated tape..	—	—
Overall diameter and weight of core.....	15	2003

nected to the cable armoring by means of a special joint some distance from the shore. As is usual, a lead sheath over each core is provided just at the landing place. The customary serv-

<sup>4</sup> *Electrical Communication*, April, 1931, p. 227.

<sup>5</sup> *A. I. E. E. Trans.*, Vol. 41 (1922), p. 1.

<sup>6</sup> *Electrical Communication*, April, 1931, p. 234.

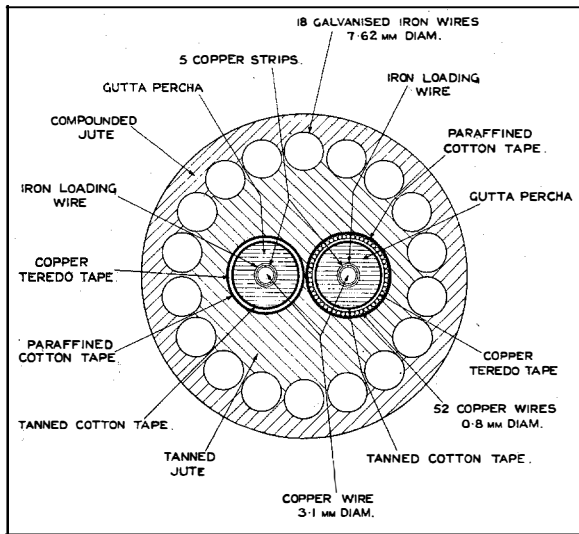

Figure 2—Cable Cross-Section, Type A2.

the coils of core were served and joined up in the lengths shown in Figure 7, each of which was armoured in one continuous operation.

The method of jointing the return wires is shown in Figure 8 and the method of terminating the sea earth core in Figure 9.

### Design of Land Cable Circuits

Although the concentric design of cable is ideal from the mechanical point of view for the submarine portion of the route, it is liable to pick up interference except at carrier frequencies, owing to the circuit being unbalanced to ground. Therefore, in view of the low receiving levels to be used, it was necessary to select landing places as far removed from possible sources of interference as was practicable without unduly lengthening the route.

As the circuits connecting the cable huts to

ing of tanned jute is applied over the core to form a bedding for the armour wires. The types and dimensions of the armouring are given in Table II.

Figures 1 to 5 show the cross-section diagrams of the various types of cable and Figure 6 shows the construction of the deep sea cable.

The core was manufactured in lengths of 1 n.m. in the Bicocca (Milan) Factory of the Societa Italiana Pirelli, and was sent to the Spezia factory where the copper return was applied.

Much study was then devoted to the question of allocation, that is, the order in which the coils of core should be jointed together in order to obtain as smooth an impedance frequency curve as possible. A description of this part of the work is contained in the other paper already mentioned.

After the completion of these allocation tests,

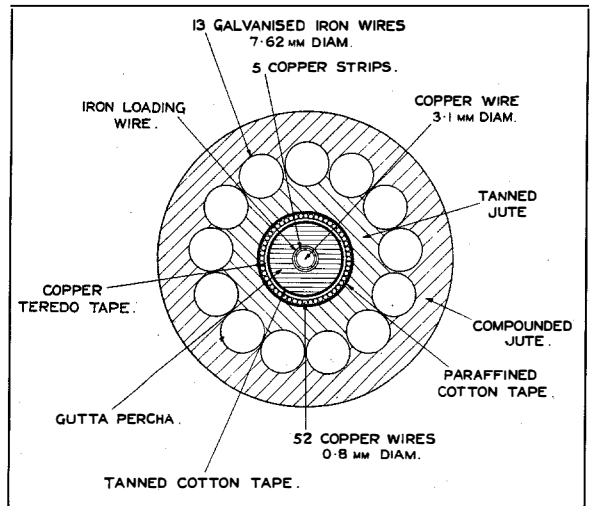

Figure 3—Cable Cross-Section, Type A.

TABLE II

Type of Cable	Description	Armour Wires			Outer Serving	Diam. mm.	Cable Wt. in Air Tons/n.m.
		No.	Gauge mm.	Material			
A <sub>2</sub> L.C.	Twin lead covered shore end	20	7.62	Galv. iron	Two tarred jutes	68	21.0
A <sub>2</sub>	Twin shore end	18	7.62	Galv. iron	Two tarred jutes	62	18.2
A	Shore end	13	7.62	Galv. iron	Two tarred jutes	50	12.0
B	Intermediate	15	5.08	Galv. iron	Two tarred jutes	40.5	7.0
D	Deep sea	24	2.41	Galv. steel	Two tarred hessian tapes	28.5	3.2

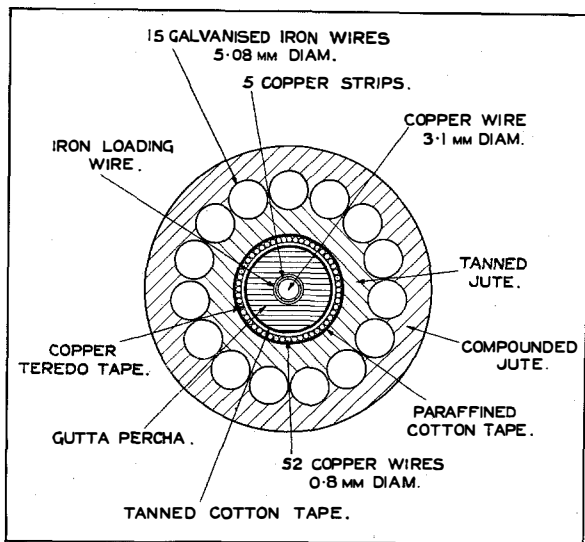

Figure 4—Cable Cross-Section, Type B.

the repeater stations were exposed to interference from power systems, concentric construction was out of the question, and it was decided to use ordinary lead-covered, paper-insulated cables for this portion of the route. The pairs used for the Italy-Sardinia telephone circuit were screened and balanced to the screen to obtain special freedom from noise. Resistance unbalances were also kept under close observation.

In view of the desirability of having high quality land lines when working in conjunction with a costly submarine cable, H-88 loading was chosen as being the most suitable. The cut-off frequency of this type of loading is 4,000 p/s, sufficient to provide for a carrier telegraph channel, while the attenuation is distinctly lower than that of H-44. Although the land line losses are very small, one is justified in considering any possible reduction in view of the rather high overall attenuation of the circuit, and for this reason fairly heavy gauge conductors were chosen for these land circuits, namely, 1.5 mm. on the continent and 1.3 mm. in Sardinia.

Another advantage of H-88 over H-44 loading in this case is that the additional time lag between Rome and the coast enables the cord circuit echo suppressor, which is situated in Rome, to discriminate more positively between west-bound speech and east-bound echoes arising

from unbalances between the submarine cable and the balancing network at the cable hut.

### Design of Equipment

The system was designed to provide two duplex telegraph channels in addition to the telephone circuit. Only the telephone circuit and the low frequency composite telegraph channel are equipped at present. The other channel could be obtained by using carrier frequencies of about 3,000 and 3,500 p/s for the two directions. In view of the demand for another telephone circuit, an effort will be made to obtain a carrier telephone channel instead of the carrier telegraph channel, if tests show that noise conditions at the higher frequencies are satisfactory.

It is of interest to note that for about a day during the installation period severe noise, which was attributed to some abnormal condition on one of the telegraph cables in the vicinity, was experienced on the voice frequency channel. The noise disappeared before its exact source was traced, but it was being picked up on the submarine cable, not the land lines. Except for this occasion, the circuit has been very quiet.

Some form of voice operated switch will be necessary on the carrier telephone channel and it may be found desirable to restrict the use of this channel to communications between Rome and

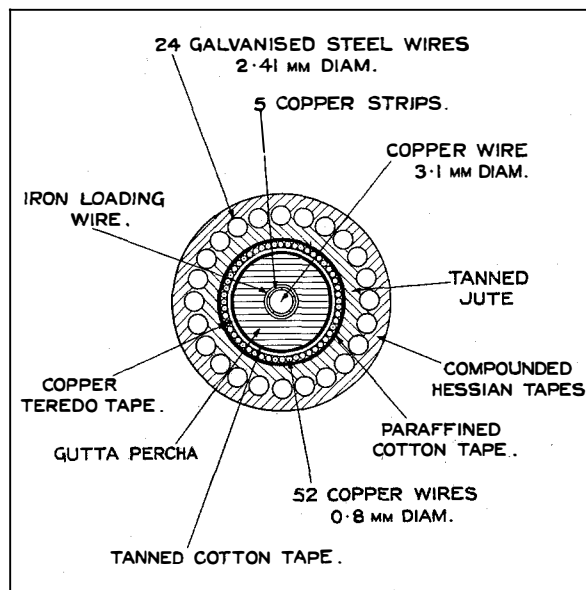

Figure 5—Cable Cross-Section, Type D.



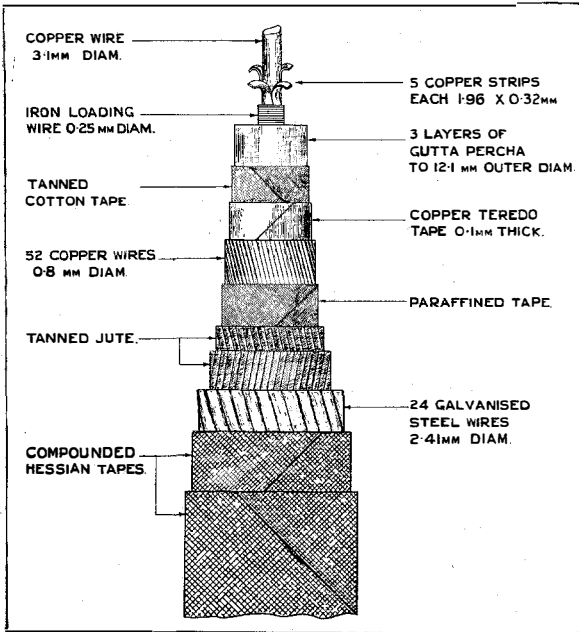

Figure 6—Construction of Type D Cable.

Sardinia, and avoid connecting this channel through to other long circuits so far as possible.

Figure 10 shows the block schematic of the new link including the open wire lines and the cables. The manner in which the carrier telegraph apparatus would have been installed is also

shown. The plans for the carrier telephone channel are not completed.

### Telephone Equipment

Figure 11 shows the overall loss characteristic of the circuit.

The transmission level diagram is shown in Figure 12. Owing to the low receiving levels, many precautions were taken to prevent noise entering the system. Apart from the use of screened circuits in the tie cables, as already mentioned, the receiving circuit was screened throughout the equipment wiring in the repeater stations and cable huts. The location of the apparatus was also carefully studied from the noise standpoint.

As some of the circuits in the cable hut were unbalanced with respect to earth, particular attention was given to the screening of the wiring at that point. Since the shields of the tie cable pairs might carry considerable earth currents, they were earthed to the armoring of the submarine cable. All unbalanced telephone circuits associated with the submarine cable were surrounded by other screens connected to the copper return conductor.

Direct connection of the land cable pairs to the concentric submarine cable would have led

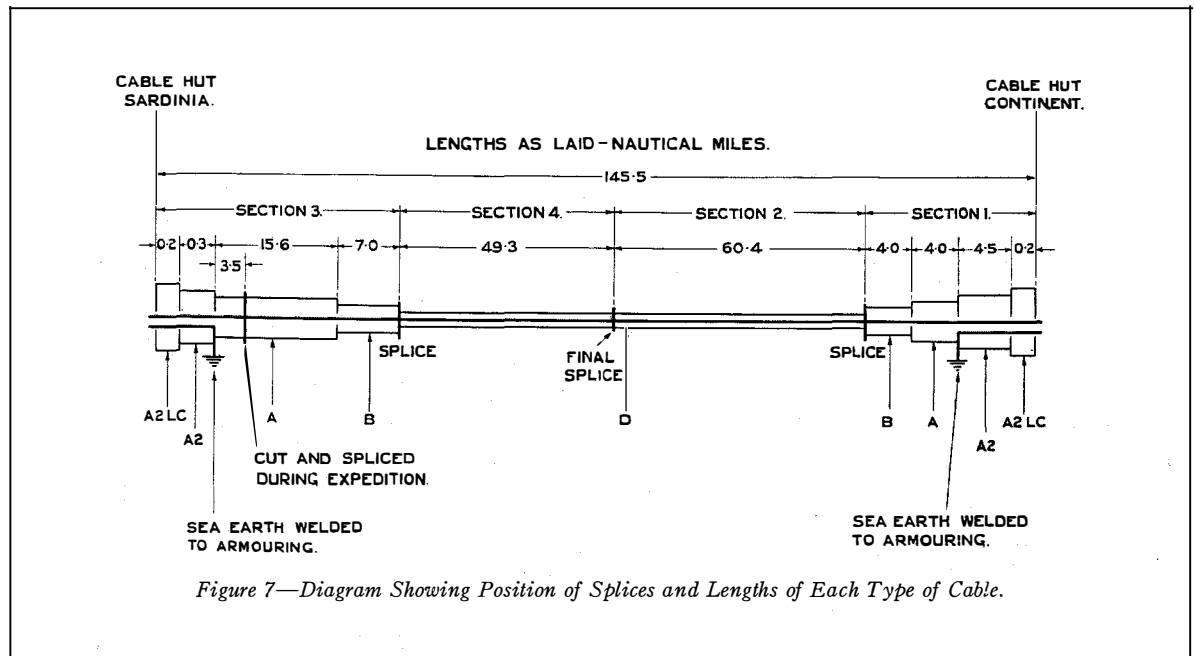

Figure 7—Diagram Showing Position of Splices and Lengths of Each Type of Cable.

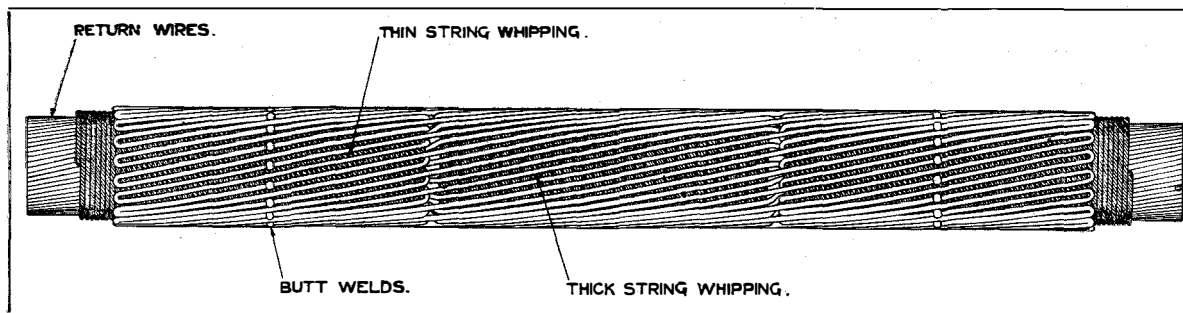

Figure 8—Method of Making Return Wire Joints.

to very considerable difficulties and in order to avoid them, four wire terminating sets and balancing networks were located at the cable huts, four-wire circuits being provided in the underground cables.

The four-wire terminating sets thus perform a double function. They form the connecting links between the two-wire and four-wire portions of the system at the actual terminals of the submarine cable, thus eliminating the singing point troubles associated with changes of temperature of the land circuits, and with differences between the impedances of the underground and submarine cable. They also act as screened repeating coils to connect the low impedance, concentric submarine cable with the high impedance metallic land circuits while, owing to their position in the circuit, changes in the magnetic properties of their cores do not affect the balance between line and network.

An incidental advantage of this arrangement is that the receiving repeating coil of the four-wire terminating set is not subjected to the heavy fluxes due to the transmitting currents of the voice and carrier telegraph channels, so that a greater freedom from modulation is obtained than is the case when a repeating coil is inserted in the two-wire part of the circuit.

The amplifier equipment consisted of modified four-wire repeaters, the transmitting halves of which were adjusted to give a flat gain frequency curve with a cut-off frequency beyond 2,500 p.s. This was accomplished by using the "medium heavy" setting in conjunction with a damping circuit. The receiving gain curve was also obtained by using the "medium heavy" setting, an equaliser being used to reduce the concavity of the normal curve.

The four-wire terminating equipment and voice frequency ringers on the office side followed more or less normal practice. Rome and Sassari are the terminals of both the telephone and telegraph circuits, the latter town being connected to the Sardinian repeater station by open wire lines. Connections can be made to other toll circuits by means of cord circuit repeaters. In the case of Rome, the cord circuit repeaters are equipped with grid jamming echo suppressors. With this arrangement, when any two long distance circuits which are not equipped with echo suppressors are switched together at

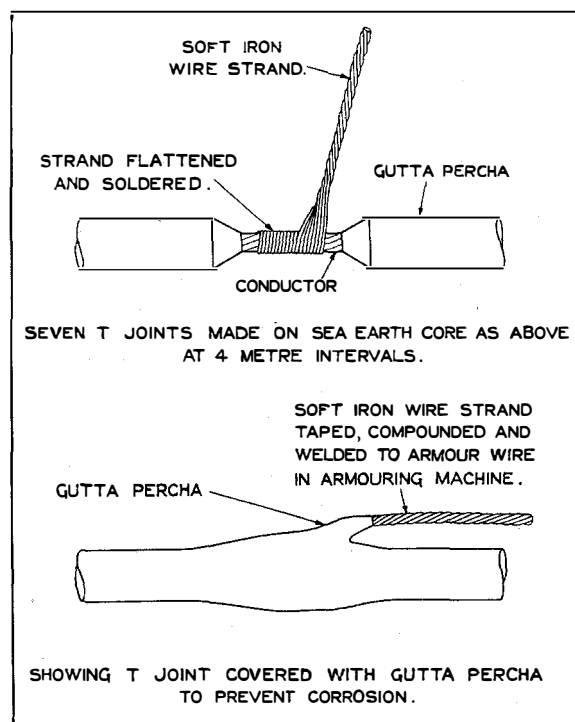

Figure 9—Method of Making Sea Earth Termination.

Rome, the echoes which would otherwise become disturbing on the switched connection may be suppressed by a comparatively few units of equipment provided specially for such cases and, therefore, used efficiently. The echo suppressors are not provided specially for the Italy-

Sardinia circuit, which is merely treated as one of a number of long distance circuits.

**Telegraph Equipment**

It was, of course, necessary to use very small currents for the composite telegraph in order to

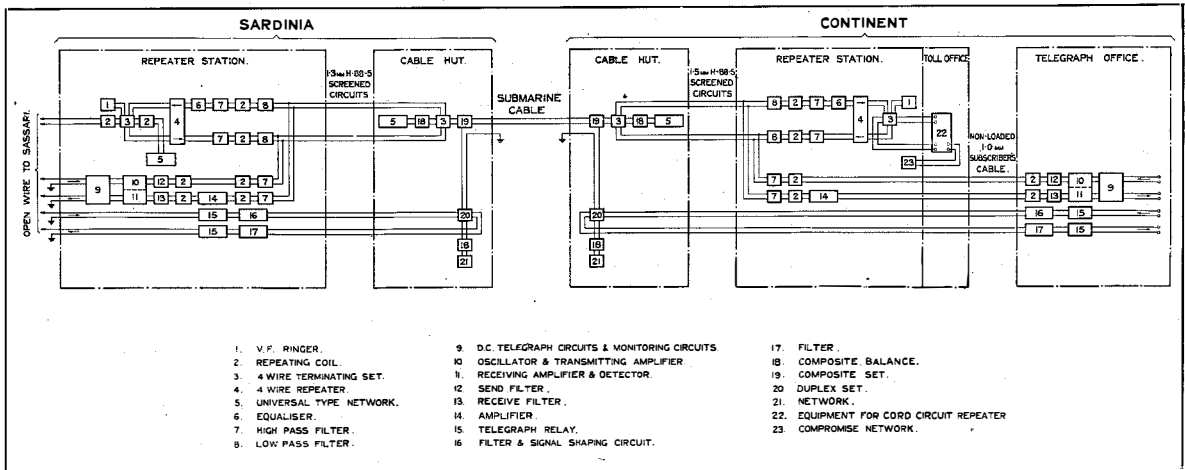

Figure 10—System Schematic of Terminal Equipment.

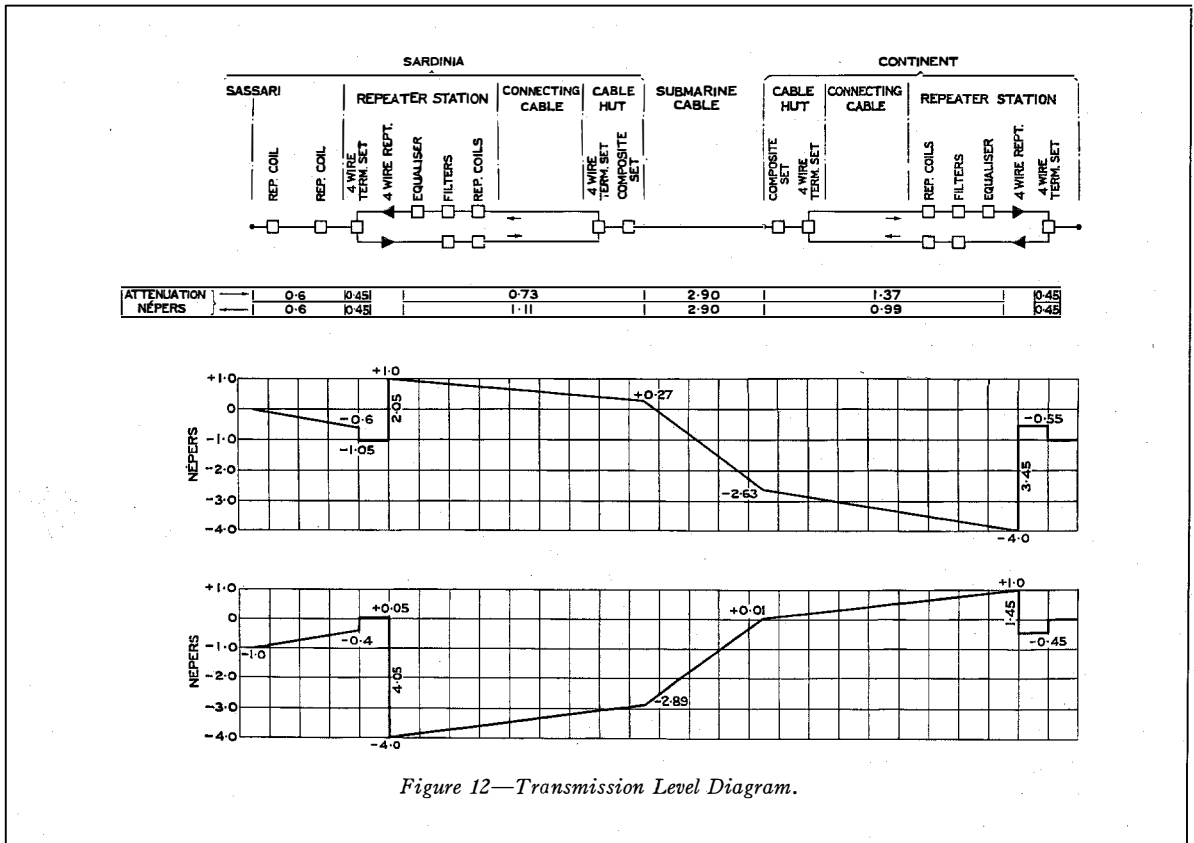

Figure 12—Transmission Level Diagram.

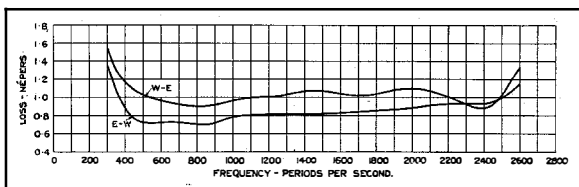

Figure 11—Overall Loss-Frequency Curves of Repeated Circuit.

external return conductor at the cable huts.) The artificial lines are installed in the cable huts. With this arrangement the duplex balance is not dependent on the conditions of the tie cables.

Wheatstone signals were successfully transmitted over the telegraph circuit in duplex at 50 bauds; it was also found possible to work

avoid interference with the telephone circuit. This involved the use of metallic telegraph circuits in the tie cables to protect the telegraph channel from external interference. As it was necessary to connect these balanced circuits to the unbalanced submarine cable, a system employing impulse telegraphy was chosen so that a four-wire terminating set could be employed to effect the connection. The effects of steady earth currents in the submarine cable are also avoided by this means. The action of fluctuating earth currents is diminished by connecting the telegraph earth lead of the cable hut equipment to the sea earth conductor in the submarine cable. (The telephone circuit is earthed to the



(Top—Right) Passing the Sardinian Shore End from the "Citta di Milano" into a Lighter.

(Center) Laying the Italian Shore End.

(Bottom—Left) Preparing to Lay the Italian Shore End from Lighter.

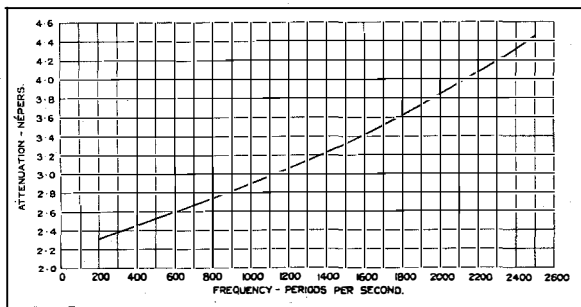

Figure 13—Attenuation-Frequency Curve of Cable After Laying.

Creed teleprinters in duplex over the circuit.

**Laying of the Submarine Cable**

The laying of the submarine cable, which was planned to start on the 16th April, 1932, was delayed by bad weather until the 22nd April, and was finished on the 28th April.

The naval cable ship "Citta di Milano" was used for the expedition. The ship was anchored about 1 n.m. from the cable hut on the mainland and the shore end cable coiled into a lighter, which was subsequently towed to the shore, paying out the cable as it went. The ship then proceeded to pay out the remainder of the sections 1 and 2 (see Figure 7), which had already been spliced together. After buoying the end, the ship then set out for Sardinia, and anchored about four miles from the cable hut. A length of 4 n.m. of the shore end cable was turned over

in the ship's tanks, cut off and coiled into a lighter, from which it was laid from the shore towards the ship, as is usual with long shore ends.

The shore end was then spliced to the remainder of section 3 on board the ship, after which sections 3 and 4, already spliced together, were laid to the buoy attached to the Italian end already laid.

Upon arrival at the buoy, the end of the Italian half of the cable was picked up and the surplus portion of type D (1.394 n.m.) was cut off from the Sardinian half. After the usual electrical tests on the two sections, the final splice was made and slipped at 9:03 p. m. on the 28th April, 1932.

The successful laying of this very heavy cable in depths of over 1,000 fathoms by a comparatively small cable ship is an achievement which was only made possible by the careful planning of the cable engineers and the able collaboration of the officers and men of the "Citta di Milano," of which they may be justly proud.

**Acceptance Tests**

During the D.C. acceptance tests which were carried out one month after laying, the following values were found:

- Insulation Resistance after 1 min. electrification, 116.7 megohms, or 17,012 megohms per n.m.
- Improvement in Insulation Resistance after 20 min. electrification, approximately 35% as obtained in the factory.

TABLE III

Cable	Date Laid	Length		Maximum Depth Fathoms	Core Weights—Pounds Per n.m.		
		Nautical Miles	Kilometres		Central Conductor	Gutta Percha	Return Conductor
Sicily-Lipari.....	1920	29	54	400	185	158	(a)
Key West-Havana (3 cables)....	1921	105	195	1000	350	315	850
Catalina Is., California (2 cables).	1923	23	43	500	350	{ App. 500 (b)	App. 850
Algeciras-Ceuta.....	1929	20	37	500	405	450	750
Tenerife-Gran Canaria.....	1929	40	74	1500	405	450	750
Key West-Havana.....	1931	109	202	1080	505	677 (c)	845
Italy-Sardinia.....	1932	146	270	1140	370	409	980

(a) Figures not available. (b) Rubber Insulation. (c) Paragutta Insulation.

Capacity of principal conductor, 46.82 mfd., or 0.3212  $\mu$ F n.m.

Resistance of line conductor,<sup>7</sup> 420.6 ohms, or 2.885 ohms n.m.

Resistance of sea earth conductor Sardinian end, 1.4 ohms.

Resistance of sea earth conductor, Italian end, 13.7 ohms.

<sup>7</sup> From which value by comparison with factory measurements at 75°F, it is to be assumed that the mean temperature of the sea along the route is about 56.7°F.

Figure 13 shows the attenuation of the cable measured by the open circuit-short circuit method, after laying.

### Conclusion

By way of comparison Table III is given, showing particulars of this and other concentric type telephone cables which have been laid up to the present.

For the information used in the preparation of this article, I am indebted to the Societa Italiana Pirelli, the International Standard Electric Corporation and the Istituto Sperimentale delle Comunicazioni, Sezione Postale Telegrafica Telefonica.



# A New 120 kW Vacuum Tube

By W. T. GIBSON, M.A., O.B.E. and G. RABUTEAU

## *Introduction*

**T**HE rapid increase in the power of broadcast transmitters during the last few years has been remarkable and at the present moment there are stations which radiate 120 kW carrier power and in which the peak power in the antenna may reach 480 kW with 100% modulation.

The 120 kW station installed at Prague uses 12 vacuum tubes in parallel in the last radio frequency amplifier stage, each tube giving a peak power of 40 kW.

Unfortunately, the use of large numbers of high power vacuum tubes in parallel is attended with many difficulties and the number that can be conveniently coupled in this way soon becomes limited. One of the chief troubles is the "Rocky Point Effect" (so named by the engineers from the station at which it was first experienced) which is a curious discharge which occurs occasionally when tubes are used at voltages higher than 10,000. This trouble is greatly reduced by special precautions and treatment in manufacture but there remains a certain small probability of its occurrence, and the greater the number of tubes in parallel the greater the probability of the effect appearing in the station.

The usual form of the effect is that in a tube operating normally, with normal characteristics and vacuum, a discharge passes suddenly, without any preliminary warning signs, between anode and grid or filament.

With well designed tubes and in the proper circuits the discharge has no after effects, and the tubes can be put into service again immediately in nearly every case. These discharges, when they can be seen, usually appear as very thin streaks of brilliant light similar to a fine incandescent tungsten filament surrounded with a violet coloured sheath.

If the conditions of the discharge and the circuit characteristics are such that the gas pressure in the tube does not increase or increases only to a minute extent the discharge ceases without

causing any damage. On the other hand, if the pressure increases rapidly the discharge may degenerate into an arc. This usually has no after effects but sometimes leads to the destruction of the tube. The effects are much less dangerous when the power supply circuit has poor regulation.

The starting of the arc type of discharge, if accompanied by oscillations having a wavelength of several metres, causes very high voltage overloads in the supply circuit and often the jumping of sparks across the turns of the choke coils with consequent possibility of a similar discharge in a neighbouring tube.

The greater the number of tubes in parallel, the greater the probability of a discharge. Furthermore, the greater the ratio of the short circuit current of the supply circuit to normal anode current, the greater the danger of destruction of any tube at the time of discharge.

The probability of discharges is greatly reduced by special precautions in exhausting and also by high voltage treatments after exhaust. With properly designed supply circuits, it is then possible to operate twelve or sixteen tubes in parallel at 20,000 volts on the anode with very little difficulty. Thus the Prague station uses twelve tubes of 40 kW peak power each in parallel in the last stage of the amplifier.

On account of these troubles a new tube having a much higher rating has been developed so that the number of tubes in parallel can be reduced. In developing this tube it was decided after careful study that the most generally useful size would be 120 kW in view of the usually standardised broadcaster sizes. This permits a 60 kW station to be built with 2 tubes in push-pull or a 120 kW station with 4 tubes, in a very simple manner.

There are two means of attacking the problem of building a more powerful tube, one being to group together in one tube the elements of several tubes of smaller size. This is not very satisfactory as all the difficulties of parallel operation of large banks of tubes still remain

localized in one tube, and the possibility of protecting each tube separately is much more difficult. The second method is to try to build a tube in which all the materials are used more efficiently, that is to say, the power dissipated per square centimetre by the elements of the tube is increased.

Having adopted the second method, there are two ways of constructing the tubes—one in which the vacuum is obtained during manufacture of the tube and is then maintained during its life, and the other in which the vacuum is continuously maintained during its life by means of a pump, the tube usually being made demountable. Recent developments of condensation pumps using oil vapour have opened new possibilities in this direction, but a very careful study showed that the continuously pumped demountable type would only be justified for considerably higher ratings, for example, at least 500 kW.

The purpose of this article is to describe the construction and manufacturing processes of a tube developing 120 kW high frequency power in which every part has been carefully studied for use at maximum efficiency and with dimensions reduced to the minimum with a view to employment on short waves. In the course of the investigation information was collected for the manufacture of a more powerful tube of 250 kW high frequency power working without discharges, an achievement which seems quite possible from the results of the tests of the tube under consideration.

### *Description of 120 kW Tube*

The general appearance of the tube is shown in the accompanying illustration. It consists of a tubular anode open at both ends and sealed to two glass bulbs, the one supporting the grid and the other the filament. The anode is a copper tube of 80 mm. internal diameter and 340 mm. long and the glass bulbs are of 105 mm. diameter. Two screens protect the two copper glass seals from the thermal radiation from the internal electrodes, from electron bombardment and also distribute uniformly the electrostatic field to the anode.

The grid is supported by a copper tube which traverses the upper bulb and serves also as an electrical connection capable of carrying 200

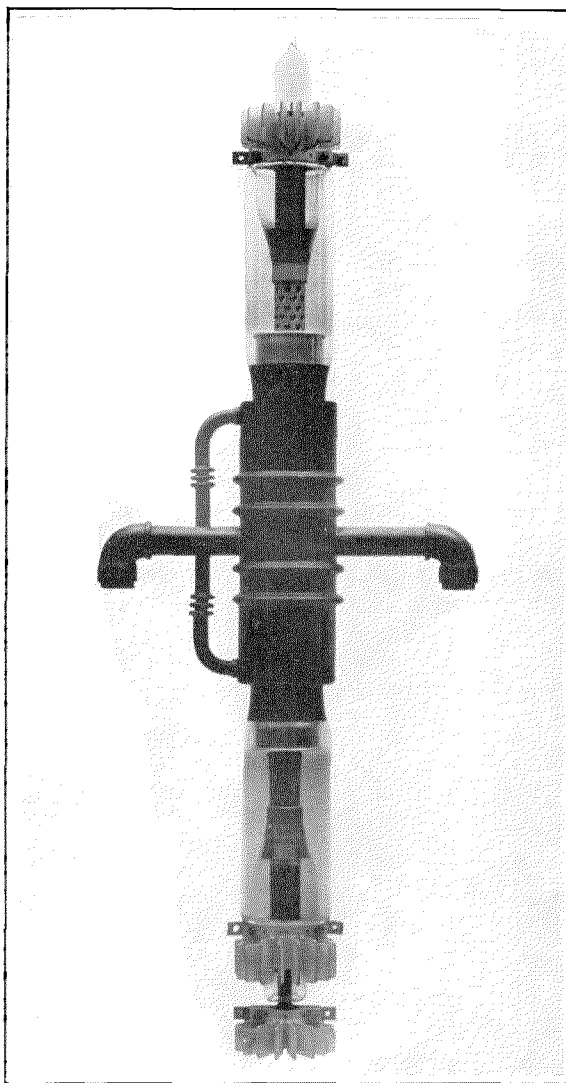

*New 120 kW Vacuum Tube.*

amperes of high frequency current, and as a means of carrying a part of the 6 kW dissipated on the grid during the exhaust of the tube. The part of the copper tube situated inside the bulb is perforated with holes to diminish the weight. The end of the grid support tube is sealed to a glass bulb which is used to connect the tube to the glassware of the exhaust station during manufacture. An aluminum radiator is fastened to the grid support tube to cool the copper glass seal. The effect of this radiator is so pronounced that the difference of temperature which exists between the copper seal and the radiator is about 100° C. for a grid dissipation of 1500 watts.

The measurement of this temperature leads to an approximate knowledge of the power dissipated on the grid and so to an indication of the grid secondary emission, which is always a difficult thing to measure in this type of tube.

The filament consists of six strands of tungsten arranged so as to form a hexagonal prism. The filament leads consist of two concentric copper tubes sealed to the lower bulb. The six strands of filament are connected two by two in series and the three U's thus formed are connected in parallel between the filament leads.

The upper ends of the three U's forming the filament are connected by a system of universal joints to a rod sliding in the axis of the grid support tube, and insulated from it. This rod is under tension applied by a spring located in the coolest part of the tube at the top of the grid support tube. The load applied by this spring and the system of joints assure a sufficient

tension on the filament strands to compensate the electrodynamic effects due to the heating current and the electrostatic forces.

The whole system of universal joints dividing the tension between the filament strands has been designed to work at 1000° C. without sticking or deforming. Aluminum radiators are fixed on the ends of the copper filament lead tubes and serve to cool the seals and also for current connections.

The anode is water cooled; a system of screens and joints soldered to the tube after exhaust assures a correct water distribution all around the active surface.

The water enters by a tube in the middle of the water jacket, is distributed around the anode by a circular channel and then flows outwards towards the ends of the anode from which it is collected by two outlet tubes. The water flows to the ends of the anode in thin sheets about

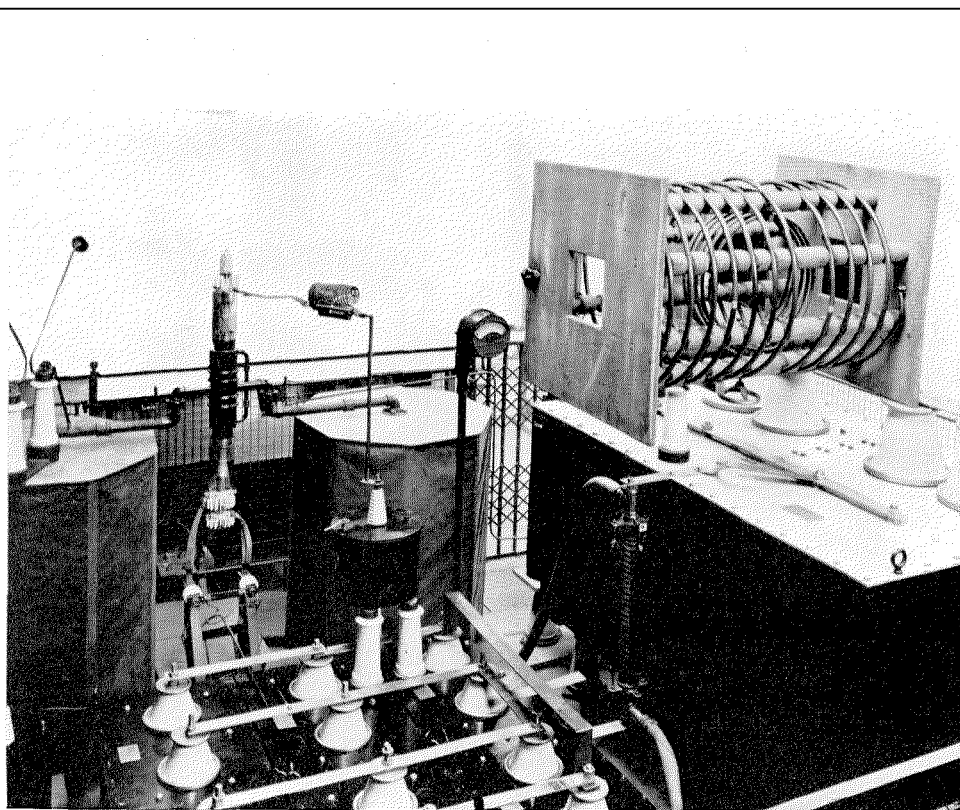

*New 120 kW Vacuum Tube Under Test*

1 millimeter thick. The section of the water passage is small compared with the section of the inlet and outlet tubes. This assures a correct distribution of the water and a very high velocity of flow, thus preventing local boiling and the noise frequently heard when water cooled tubes are working. The arrangement permits the tube to withstand a dissipation of 500 watts per square centimeter, the test dissipation for the anode being 160 kW.

The water jacket is equipped with an expansion joint which provides for taking up relative expansions of anode and water jacket during the operation of the tube.

The arrangement of the anode shields, the form of the electrodes in the tube, the care applied to the preparation of the parts, the absence of all traces of dust, the treatment of the bulbs, the methods of exhaust and of "forming" during testing allow the tube to be operated under an anode voltage of 20,000 without danger of frequent shut-downs due to discharges. During tests this voltage has often been applied 100 times consecutively with no trace of discharge.

### Characteristics

The characteristics of the tube are as follows:

Filament voltage	24 v.
Filament current	225 amps.
Anode voltage	20,000 volts
Amplification factor	32
Impedance	2,000 ohms.
Slope	16 milliamps per volt
Anode current for $E_B = 10,000$ , $E_C = 0$	1.85 amps.
Grid voltage for $E_B = 20,000$ , $I_B = 0$	-550 v.
Maximum anode dissipation	80 kW.
Test anode dissipation	160 kW.
Maximum grid dissipation	1.5 kW.
Maximum H.F. power as oscillator at 70% efficiency with $E_B = 20,000$ volts	= 120 kW.
H.F. output power on test as oscillator at 70% efficiency with $E_B = 25,000$ volts	= 200 kW.
Carrier wave power as linear amplifier, 100% modulation at 20,000 volts	30 kW.
Probable filament life	6,000 hours
Filament grid capacity	60 mmfd.
Grid anode capacity	70 mmfd.
Anode filament capacity	15 mmfd.
Length	120 cm.
Diameter	12.5 cm.
Weight	12 kilograms
Maximum water pressure in jacket	2.5 kilos per sq. cm.
Water flow	100 litres per min.
Pressure drop in water jacket at 100 litres per min.	1 Kilo per sq. cm.

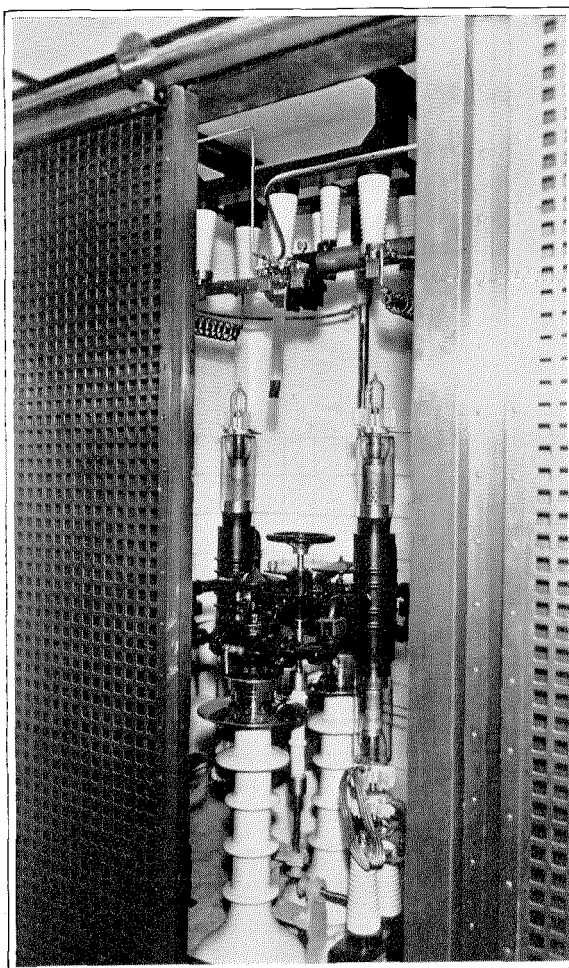

120 kW Vacuum Tube as Installed in New Kalundborg Broadcaster.

### Application

The 120 kW vacuum tube permits the construction of broadcasting stations of the highest power. Four tubes are used in the power amplifier stage of a station of 150 kW antenna power at 1000 K.C. now under construction.

The small dimensions of the tube on the one hand, and its great safety factor for overloads on the other, enable us to plan construction of 250 kW high frequency power working with an efficiency of at least 70% at an anode voltage of 20,000 volts.

Four such tubes used in parallel in a broadcaster would absorb an average power of 750 kW and would give a carrier wave power of at least 250 kW and a peak power of 1000 kW.

# The Single Side-Band System Applied to Short-Wave Telephone Links<sup>1</sup>

By A. H. REEVES

*Associate Member of the Institution of Electrical Engineers*

## SUMMARY

**I**N Part I it is pointed out that only a few of the existing 50 radio-telephone links are at present working at anything like full-load capacity. For this reason the chief problem for the engineers on most of the links is one of reducing operating costs. On a few heavily-loaded links, however, the expense of some improvement in circuit performance would be justified. Various means are discussed in outline for dealing with these two problems.

In Part II further details of the improvements proposed in Part I are dealt with, and in particular the probable value of the single side-band method in relation to other possible solutions is discussed.

(1) *Operating costs.*—It is found that on an existing typical link, either with light or heavy traffic, the single side-band suppressed-carrier system would be expected to save about 87 per cent. of the valve replacement costs, and 90 per cent. of the cost of the power.

(2) *Improved performance.*—In the cost estimates of (1) it is shown that changing to single side-band working should be equivalent in signal/noise ratio to increasing the peak power of the transmitter about 16 times. If this factor is allowed for, by greatly reducing the transmitter size, it is shown that single side-band working should still give circuit improvements in relation to fading quality and privacy. The single side-band system eliminates the chief cause of distortion at present, i.e., that due to selective fading-out of the carrier. It should also make workable several well-known privacy schemes at present useless during selective fading, and give rise to a promising new method.

A possibly new means of reducing distortion

due to intermodulation in Class 3 single side-band amplifiers is referred to.

In Part III an attempt is made to answer the following three questions:—

Is the problem technically possible at all under present commercial conditions?

If it seems possible, what is likely to be the best general method, independent stable oscillators at each end, or the use of a pilot signal?

Having decided on the most promising general method, what problems will be met in designing practical equipment, and how can we solve these problems?

The answer to the first is in the affirmative; single side-band working should be possible in practice, either by separate stable oscillators or by a pilot signal.

A discussion of the second question results in favour of the pilot method, particularly as it is shown that some sort of pilot is almost indispensable in any case, for controlling the medium-period fading.

Answering the third, it is suggested that a single radio frequency corresponding to an audio frequency of about 3.4 kilocycles per sec. would be most suitable, and that this pilot should control the frequency of a local oscillator. It is pointed out that exact synchronizing in the correct phase would in any case be useless at present; while selective fading is still not overcome, the exact signal wave-form can never be reproduced at the receiver, even with perfect carrier synchronism.

Experiments were carried out by the author on three short-wave links using equipment on the lines suggested in Part III, and the results are given in Part IV. The final tests between Madrid and Paris showed that the expected improvements over double side-band working, discussed in Part II, were fully obtained. A

<sup>1</sup>Paper read before the Wireless Section of The Institution of Electrical Engineers on May 3, 1933, and published in The Journal of the Institution of Electrical Engineers, September, 1933, Vol. 73, No. 441.

maximum synchronizing error of 6 cycles per sec. over periods of several hours was found.

In Part V it is suggested that—

- (i) A simplified form of the receiver described in Part IV could be used commercially, and would meet requirements for at least the next few years. In this connection a somewhat new form of filter, on the “balanced reaction” principle, is described.
- (ii) For the immediate future the principle used in the transmitter should be that of the “side-band balance,” i.e., a method of

selecting the side-band in one stage directly at the final high frequency, without relying on filters. This circuit is discussed.

Assuming selective fading to be absent, it is shown in Part VI that synchronizing at the exact frequency, within predetermined phase limits, is fairly simple. One form of circuit to do this is described.

A high-quality circuit is explained, giving exact synchronism in phase except during periods of deep fading, when the frequency difference may amount to a few cycles per second.



# The Condenser Cone

## A New Device for Use in Connection with High Tension Cable Terminations and Joints

By J. K. WEBB, M.Sc., A.M.I.E.E.

*Power Cable Laboratory, Standard Telephones and Cables, Limited*

ANYONE associated with the development, testing, and installation of high tension power cables will readily appreciate the special importance of problems involving joints and terminations. The essential difficulties are largely aggravated by the practical impossibility of applying mathematical analysis and of taking measurements of some of the important factors under service conditions. Any solution, also, must be reconciled with such engineering aspects as ease of installation, reliability in service, and overall economy. Such factors have been taken into account in the development of the herein described condenser cone which, it is believed, represents a definite advance on previous work in that it effects quite a startling improvement in the ability of cable ends to withstand high voltages; and it is in itself both compact and easily constructed.

Before describing this new device in detail, however, a general review of the problem will be given and mention made of some of the devices which have been previously adopted.

*Plain Ends.* A high voltage cable is usually prepared for voltage and power factor testing by stripping the lead and metallised paper away from the ends to a distance amounting at times to several feet. When voltage is applied to the cable and raised in value, visible signs of stress concentration at the termination of the lead sheath will occur. The initial corona rapidly increases to a vigorous sparking which soon results in flashover.

Concentration of stress is caused by the capacity interlinkage which exists between the core and the sheath. Due to the exposure of the dielectric at the end, slight contamination with dirt and condensation of moisture on its surface will give rise to a high resistance leakage path. Unless this is quite abnormally low, however, the stress distribution will hardly be affected,

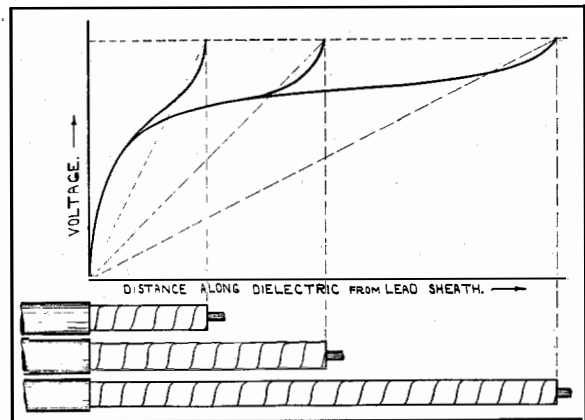

Figure 1—Curves illustrating the distribution of voltage along the surface of the exposed dielectric at a cable end. It will be noticed that increasing the length of test end does not decrease the voltage gradient near the sheath.

but the tangential component of the latter will cause deterioration. Thus, plain ends oil immersed in end-bells, working at ordinary service voltages, frequently present the appearance of having been "moth-eaten" after one or two years due to the action of this tangential stress. Immersing a plain end under oil, it should be noted, does not correct the lack of uniformity of the stress distribution.

The variation of voltage gradient along the surface of the dielectric between the lead sheath and the core has been examined in detail by Dr. Ing. A. Schwaiger who gives the results of measurements made under various conditions.<sup>1</sup> For the case of a power cable the general form is that given in Figure 1 which shows the distribution of potential for different lengths of exposed end, the applied voltage being the same in each case. It is seen from this figure that the main voltage gradient occurs in that region most proximate to the lead sheath, while it approaches zero over a considerable portion of the remaining length. This explains why it is that after a cer-

<sup>1</sup>For numbered references see Bibliography.

tain length of test end is reached, any further increase in the length will hardly affect the flash-over voltage, since the middle length of dielectric does not make any sensible contribution towards absorbing the gradient. Any device, therefore, designed to increase the spark-over voltage must aim at making this voltage gradient more uniform along the length of exposed dielectric.

While it is true that with increasing voltages the stress distribution improves, this apparent improvement is due to the formation of corona discharge at the termination of the lead, causing a resistance grading effect similar to that described later under the heading of "Semi-Conducting Paper." The corona, however, soon deteriorates the insulation which leads to early breakdown.

**Metal Cones.** An early attempt to avoid stress concentration at the termination of the lead sheath was made by using spun metal cones mounted over the end of the cable and taking one or other of the forms illustrated in Figure 2. This formed the subject of a patent<sup>2</sup> taken out in 1922 by Societa Pirelli & Co. The ideal shape (Figure 2a) which can be found by means of mathematical calculation is, however, a trumpet which becomes so enlarged at the top that it is unpractical. It is therefore usual to adopt an abbreviated form as illustrated in Figure 2b, and while such cones have long been popular they can only be said to effect a very slight improvement over the plain end. Very often the cones are simply made with a straight taper (Figure 2c) and in all cases are filled with insulating compound.

**Reinforced Insulation.** A favourite method of attempting to strengthen an end is to increase the dielectric thickness from the termination of the lead sheath, such increase taking the form of a more or less gradual taper which is covered with an electrostatic screen in contact with the sheath. This arrangement is illustrated in Figure 3.

In common with plain metal cones, this effects some improvement under general service conditions when the end is mounted in an oil filled end-bell and is in general use at the present time, e.g., the Pirelli Terminal and the General Electric Terminal.<sup>3</sup> While the increase of dielectric at the end obtained in this way increases

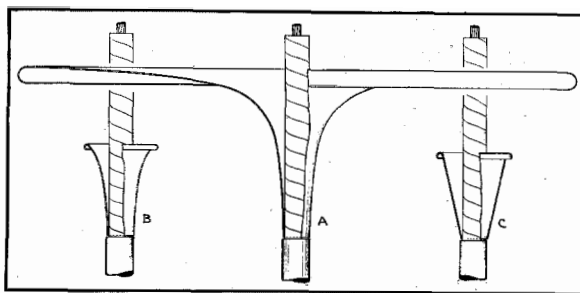

Figure 2—Compound filled metal cones at sheath potential used in attempting to grade the stress at cable ends. A is the most ideal but rather impractical. B is a compromise which, however, effects very little improvement on a cone with a straight taper as in C.

somewhat the time to puncture, deterioration at the end is apt to occur in course of time due to the tangential component of the stress.

For the factory testing of cables, when they are put on considerable overvoltage and the ends are in the open, the added strength afforded by either of these methods is so slight as almost to discount their value entirely. In certain special cases, however, in which time and cost are of minor importance, a greatly increased strength may be obtained by making the taper sufficiently gradual and the relative increase of dielectric thickness sufficiently great. Such cases usually apply to small experimental samples as, for example, those tested by J. B. Whitehead and F. Hamburger, Jr.<sup>4</sup> where the voltage is only of the order of 50 kV. In routine testing it is above 100 kV that the problem becomes acute.

**Semi-Conducting Paper.** The use of semi-conducting paper such as that used in roll-film holders, wrapped round the dielectric in the vicinity of the sheath has been adopted with some success.<sup>5</sup> The full description of its practical application will be found in the paper cited, although its sphere of usefulness seems to be restricted to pressure testing for short periods rather than life tests and general service. Besides paper, semi-conducting paints composed of shellac and carbon also have been used.

It is not theoretically possible, however, to obtain a uniform voltage gradient by means of resistance as the following analysis will show. Figure 4 illustrates diagrammatically the exposed end of a power cable whose core is at potential  $E$  and which has a distributed capacity  $C/cm.$  to the surface of the dielectric. The latter is sup-

posed to be covered with a film of some material having an impedance  $Z/cm.$  at any point.

For the case of a uniform voltage gradient along the whole surface, the equations are:

$$-\frac{dE}{dx} = ZI = -k \dots \dots \dots (1)$$

$$-\frac{dI}{dx} = j \omega C E \dots \dots \dots (2)$$

where  $k = \text{constant}$   
 $j = \sqrt{-1}$   
 $\omega = 2\pi \text{ frequency.}$

Hence  $E = k x$

and  $-\frac{dI}{dx} = j \omega C k x$

$\therefore I = \frac{1}{2} j \omega C k x^2 = k/Z$

and  $Z = \frac{2}{j \omega C x^2}$

This result shows that the nature of the surface impedance  $Z$  required to obtain a uniform voltage gradient should not be a resistance but be composed of a capacity whose value varies directly as the square of the distance from the end. It would, besides, be very difficult to apply a graded resistance and even if this could be done the resistance per cm. of surface to flashover would be decreased and the problem of the dissipation of the heat generated in the resistance might arise. The maximum stress which can exist along the surface of an impregnated cable open to the atmosphere is about 19 kV/inch but the application of a semi-conducting film lowers this value considerably.

*Plain Ends Oil Immersed.* Immersing an end in oil effects a great improvement, mainly because its breakdown strength is much greater than that of air, but also partly because its higher dielectric constant causes a certain favourable redistribution of the stress. This method is frequently adopted for pressure testing, and has been used by the author for several years. The oil may be contained in a large metal tank and in order to make connection with the cable core, a lead-in through a condenser bush-

ing is arranged in the side of the tank (Figure 5).

The size of the oil container is, however, very great for supertension cables, thus making the method rather cumbersome, and provision also has to be made for filtering the oil should breakdown take place. Under service conditions the cable ends are, of course, oil immersed in end-bells, but with the modern tendency to reduce dielectric thickness, the added stress concentration at the termination of the lead sheath in the end-bell tends to make it the weakest point in the system. Dendritic markings are frequently found on the surface of the dielectric at the termination of the sheath after a long period of service voltage and when pressure testing, actual burning is frequently observed. In addition, very long ends are required and this fact,

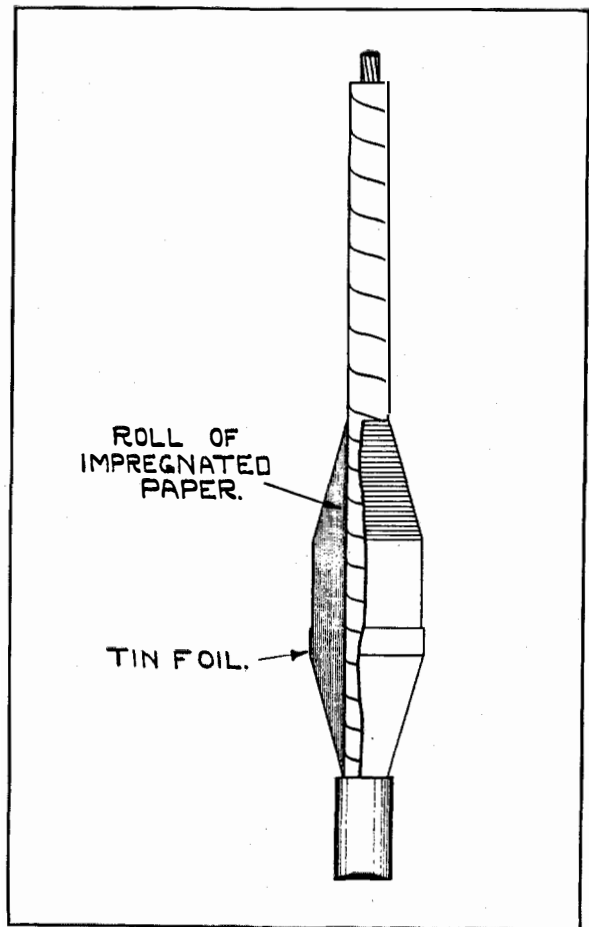

Figure 3—Cable end with reinforced insulation. In practice it is difficult to avoid leaving a gap between the cable dielectric and the added roll of insulation, along which breakdown often occurs.

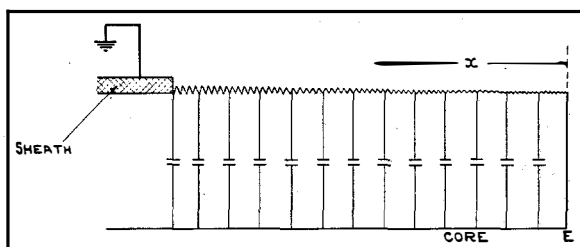

Figure 4—Diagram to illustrate surface impedance of exposed dielectric with distributed capacity to core.

together with the acute nature of the stress distortion, makes the dimensions in the design of potheads needlessly large.

**"Tails" with Intersheaths.** A cable in which intersheaths are incorporated simplifies considerably the problem of termination, since by the progressive termination of the intersheaths along the tapered surface of the exposed dielectric (Figure 6) the total voltage between core and sheath may be split up into a number of increments proportional to the number of intersheaths. Thus, if there are  $n$  intersheaths between diameters  $a$  and  $b$  at diameters  $d_1, d_2, d_3, \dots$ , such that the voltage between each is  $\pm V/(n+1)$  where  $V$  is the voltage between  $a$  and  $b$ , then the ratio  $R$  between two consecutive diameters is constant and is given by:

$$R = \frac{d_1}{a} = \frac{d_2}{d_1} = \frac{d_3}{d_2} = \dots = \frac{d_n}{d_{n-1}} = \frac{b}{d_n}$$

and the various diameters at which the intersheaths should be located are

$$d_r = aR^r, \text{ where } 1 \leq r \leq n.$$

A short length of intersheath cable may be jointed to a length of non-intersheath cable in order to effect its termination, but the method is very cumbersome and there is still the difficulty of making a satisfactory joint between the intersheath and non-intersheath cable, since the ungraded termination of the main cable in the joint is subjected to concentration of stress.

**Capacity Grading.** Various capacity grading devices have been suggested, most of which are described by Schwaiger.<sup>1</sup> Usually, the capacities may be arranged theoretically to give a uniform gradient, but it is difficult in practice to make them large enough so as firmly to anchor the potentials which they are supposed to assume,

without making the design unduly cumbersome. This is due to the effects of small leakances and the presence of any slight discharge or corona which might form at higher voltages, such disturbances becoming cumulative in character.

One of the earliest forms of capacity grading was described by Farmer.<sup>6</sup> It consists of a stack of discs strung on to the cable end as illustrated in Figure 7. The top disc is connected to the conductor and the lower one to the lead; each disc consisting of an annulation of dielectric material metallised on one side. The diameters are arranged to give equal increments of potential across each disc.

This arrangement met with partial success and was developed by Atkinson<sup>7</sup> of the General Cable Corporation, New York, who has succeeded in making the design more compact by supplementing the discs with proportioned condensers. From published accounts such terminations have given good results on test, and the only criticism which can be offered must be directed towards the question of ease of installation and cost. Data on these questions are however, not available.

### The Condenser Cone

This device, which has been developed in the power cable laboratory, Standard Telephones and Cables, Limited, besides good electrical characteristics, possesses the added advantages that it is

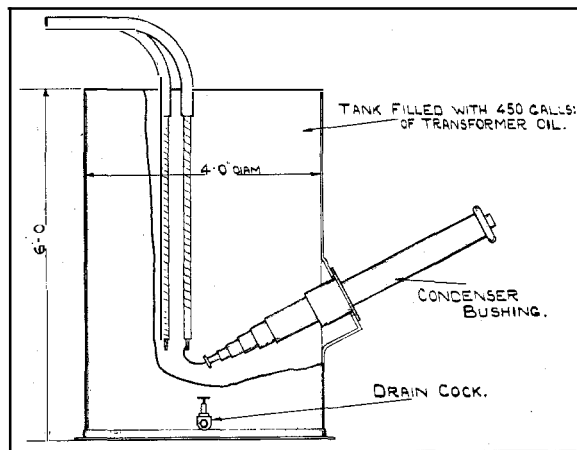

Figure 5—Factory method of dealing with ends for pressure testing of cables, which has proved useful in the past. Very high voltages cannot be achieved and it is often difficult to manoeuvre the two ends into the tank, e.g., when the cable is on a drum.

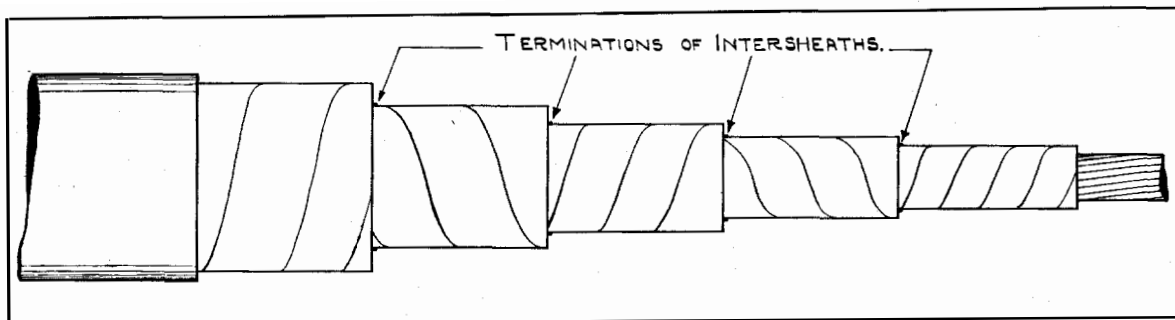

Figure 6—Termination of a cable containing four intersheaths. The voltage can thus be divided into five equal increments which greatly simplifies the problem of termination for such cables.

cheap to construct, easy to install, and has a wide range of application. It is based on the principle of capacity grading which is sound enough, but the method of displacing the condensers is novel. The method of construction is shown diagrammatically in Figure 8, the diametral scale being exaggerated for the sake of clearness. A series of concentric metal cylinders is arranged in the manner shown, the outermost cylinder being connected to the cable core and the innermost to the sheath. When voltage is applied to the core and the sheath earthed, the potential of each cylinder will be governed by the values of the interlinking capacities, and these may be adjusted to give an equal increment of voltage across each pair. The resultant redistribution of the stress configuration will result in a uniform gradient along the dielectric. The effect is illustrated in Figure 9 which shows how the stress lines, initially concentrated at the termination of the lead sheath, are spread out in a more even manner. Figure 9a shows a bare end, the stress lines becoming very dense at the lead sheath and (b) the same end after fitting with a condenser cone; the stress lines are now more evenly distributed.

To determine the values of the capacities to fulfill the ideal conditions, it will be observed that associated with each cylinder there are three capacity interlinkages to consider, the main one being its capacity to the proximate cylinders. The other two capacities are those to the core and earth from the projections of each cylinder beyond its neighbours. In practice the capacity to earth is negligibly small and it is sufficient to make a small allowance for the capacity to the core which may be assumed equal to the mean value for all cylinders. We thus arrive at the

schematic given in Figure 10 as representing sufficiently the practical case.

If  $8V$  is the voltage drop across each condenser, we have that

$$8V = \frac{I + [1 + 2 + 3 + \dots + (r-1)]i}{j \omega C_r}$$

$$\begin{aligned} \text{where } I &= j \omega C_1 \delta V \\ i &= j \omega C_0 \delta V \\ \omega &= 2 \pi \text{ frequency} \\ j &= \sqrt{-1} \end{aligned}$$

$$\text{whence } C_r = C_1 + \frac{r}{2}(r-1) C_0 \text{ where } 1 \leq r \leq n$$

The justification for assuming that the capacity to the core of the projection of each cylinder can now be seen from this equation since in most practical designs the value of the term  $\frac{r}{2}(r-1)C_0$  is only about 30% of  $C_1$ .

In designing a cone, it is easiest first to fix on the dimensions which determine  $C_n$ , the remaining factors being chosen empirically but so that the above equation is satisfied. It is desirable from the point of view of ease of construction to have a straight taper on both the outer and inner cones, and this is quite possible without deviating very far from the rigid mathematical dimensions. A great latitude is thus allowed in fixing the main dimensions. The total length is chiefly determined by the external flashover voltage and the inner cone by the internal flashover. It will be found that for a given length the longer the inner cone is made, the shorter will be the metal former and also the length of the outer foil for a given diameter. This latter is made as small as possible, consistent with suffi-

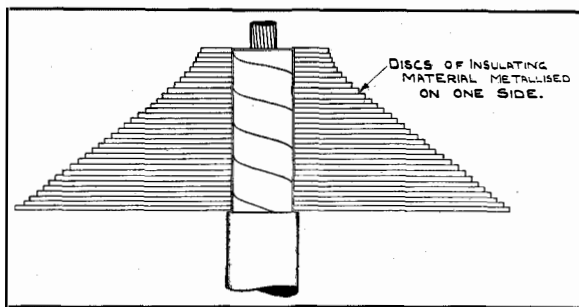

Figure 7—Early attempt at capacity grading which gave promising results although the design was cumbersome. The value of the capacity varies approximately as the square of the distance from the end.

cient dielectric strength. The number of cylinders is a function of the difference of the external diameter and the diameter of the metal former.

In order to make the cone sufficiently robust to withstand normal handling, it is constructed of a continuous spiral of paper wound on to a metal former. The intermediate metal cylinders take the form of aluminium or tinfoil placed in position during the winding operation for which a special machine has been designed. Means are taken to prevent any tendency for the completed cone to "telescope," and after drying it is vacuum impregnated in the same manner as a power cable, and stored in a tin container under oil. Special tests have been devised for checking the presence and position of foils made by mass production methods and the completed product is finally tested on voltage as in service before being passed.

*Application.* Wherever insulated conductors are jointed or terminated there are direct applications for these cones. Some of the specific uses will now be described in detail. When used for terminations, the cable ends are arranged vertically, and after applying the cone it is filled with some liquid dielectric.

*Pressure Testing.* For routine pressure testing it will generally be found quite satisfactory to fill the cone with oil similar to that with which the cable has been impregnated. In the case, however, of short time breakdown tests where it is desired to apply a voltage of anything up to about 9 times the working voltage of the cable, the difficulty arises that the stress at the surface of the dielectric at the base of the cone exceeds the breakdown value of the unbuffered

oil. This stress is relatively greater, due to the fact that the dielectric constant of the oil, being about 2.3, is considerably less than that of the impregnated paper dielectric which is about 3.8 and with which it forms a circuit in series. It would thus appear that if the cone were filled with a liquid of high specific inductive capacity, or means were adopted of effectively raising the specific inductive capacity of the oil, increased strength would result.

Experiments were made by filling a cone with a mixture of small glass beads of diameter about 3 mm. and oil. The beads have the double effect of giving an apparent increase in the dielectric constant of the filler, and also in providing a baffle for the oil. This procedure certainly effected an improvement on test, especially on voltage runs which occupied several hours and the only drawback was a certain difficulty in

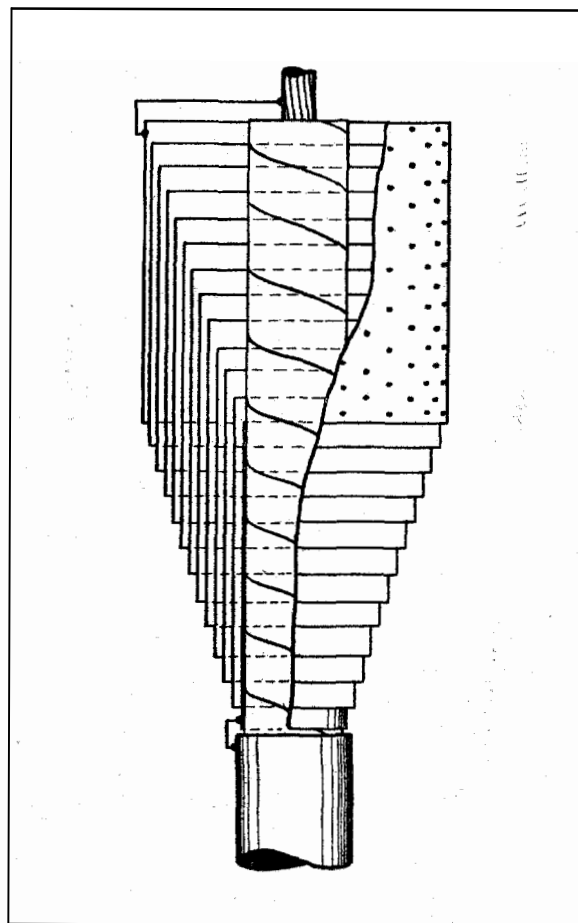

Figure 8—Diagram of Condenser Cone.

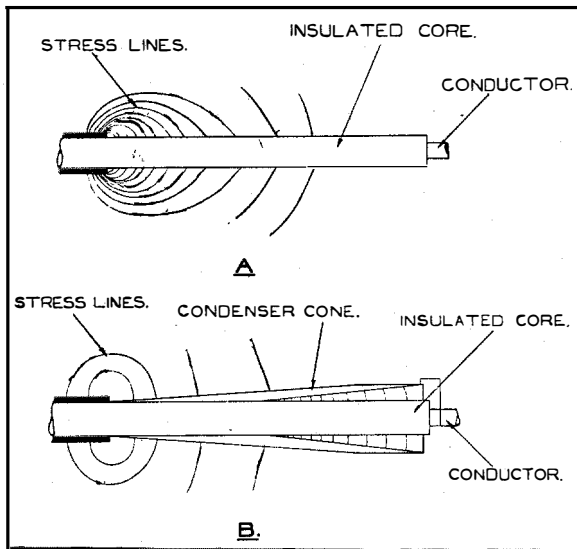

Figure 9—The distribution of electrical stress at (a) a bare end, and (b) the same end after fitting with a condenser cone, illustrating how stress concentration is thus eliminated.

removing the cones from the cable ends. Another set of tests was made using castor oil alone as the filling medium. Castor oil has a dielectric constant of 4.67 but proved a complete failure due, it is believed, to the fact that it will not readily mix with the mineral oil used in impregnating the cable. Breakdown readily occurs along the surface of demarcation of the two oils. Resort was then made to chlorinated diphenyl which appears on the market under the names of "Pyranol" and "Aroclor" but here again results were curiously disappointing although this compound has a specific inductive capacity of about 4.8, mixes readily with mineral oil, and has a high breakdown value. Finally, chlorinated naphthalene or "Halowax Oil" was tried, its specific inductive capacity being about 4.9 with other properties somewhat similar to those of "Pyranol" except for its viscosity which is much lower. This gave excellent results and very considerably increased the strength of the cones. The main objection to its use at present is its low viscosity, but it is hoped soon to find a liquid dielectric which is suitable in all respects. A filling material having too low a viscosity tends to diffuse into the cable thereby affecting test results on long runs and there is besides a tendency to leak, a minor difficulty which however may be overcome by sealing the bottom of the cone with

plaster-of-paris or rubber tape when mounted on the cable. The former is preferable when the cone is applied over the lead sheath, and the latter when over the dielectric.

It has not been found essential to centre the cable end accurately inside the cone.

When the cones are used in the open and are subjected to the highest voltages such that the external flashover value is approached, it is advisable to provide arcing rings so as to deflect the arc away from the surface of the cone, thus avoiding damage to the latter.

*Economising Ends on Power Factor Tests.* When used in this connection, the cone is made of such dimensions that it may be slipped over the lead sheath and lightly insulated therefrom by means of bitumenised tape. The inner tube of the cone is earthed while the lead sheath is connected to the Schering Bridge. By adopting this arrangement (illustrated in Figure 11), the cones act as guard-rings, and conduct any impurity at the cable ends directly to earth. In this way it has been found possible to test

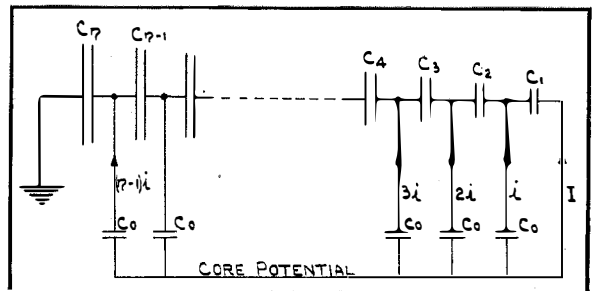

Figure 10—Electrical circuit schematic of Condenser Cone.

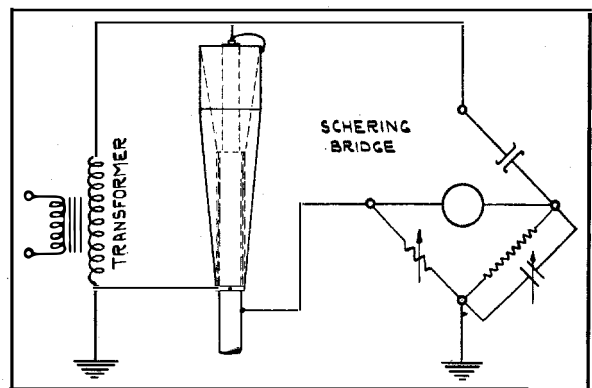

Figure 11—Method of using cone as a guard-ring so that end impurity is not included in the bridge reading. The cone in this case is lightly insulated from the sheath.



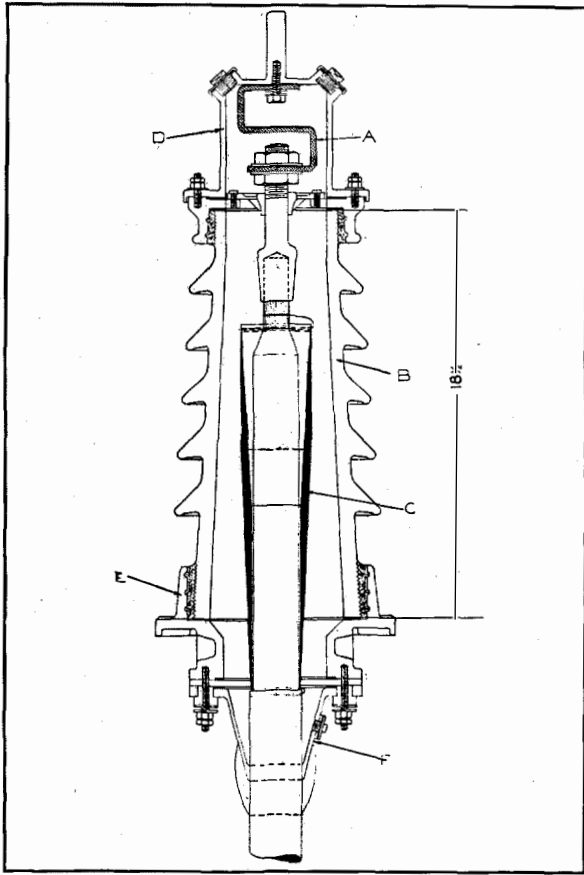

Figure 12—Cone in position in existing 33 kV end-bell. Life tested under service conditions for over a year at 83 kV without any trouble.

cables having only a 6-inch test end to over 100 kV without even showing signs of sparking, whereas the usual length of test end would necessarily be over 3 feet. Cones which fit over the dielectric may also, of course, be used as guard-rings in like manner.

It is common experience that in taking power factor tests on cables with bare ends fitted with guard-rings in the ordinary way, the discharges which take place to the latter affect the galvanometer and thus the accuracy and sensitivity of the reading. With the use of cones, however, there are no such discharges and so it is much easier to obtain true bridge balance at higher voltages.

*Life Testing and General Service.* The cones will be found conveniently to fit in end-bells as at present constructed, and Figure 12 shows a section of a 33 kV end-bell with a 16½-inch cone

in position. The criticism might be made that since the outer foil of the cone is at core potential, the cone is too low relative to the porcelain. As against this it can be stated that the particular end-bell illustrated in Figure 12, although only designed for a working pressure of 33 kV three-phase, has been in continuous outdoor service for about a year now for life testing 66 kV cables, the test pressure being 83 kV three-phase. It has rarely even been cleaned during this time, and has given no trouble at all. This represents a very considerable advance on previous experience and makes possible the cutting down of dimensions on future designs. Figure 13 shows an end-bell for 66 kV cables designed specially to accommodate a 25-inch cone.

*Joints.* In the case of joints the main weakness is generally to be found in the surface of

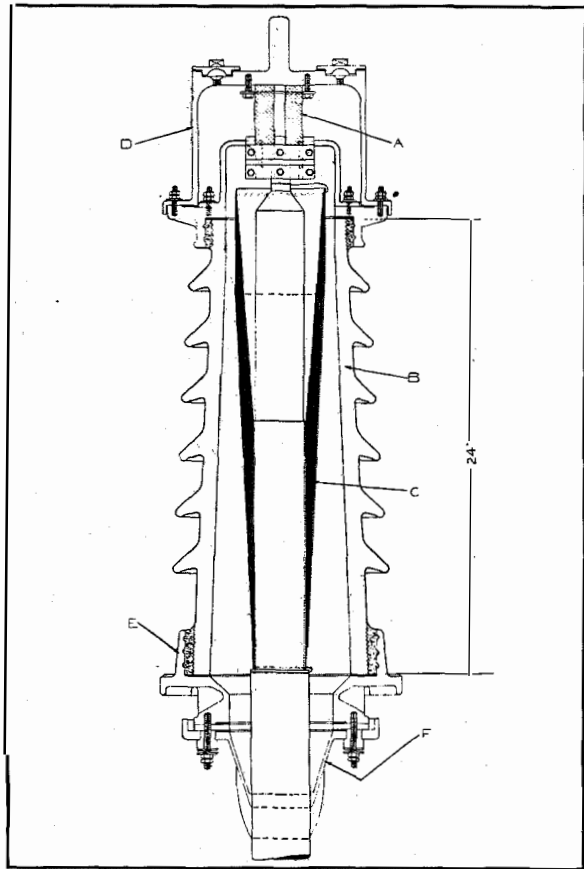

Figure 13—End-bell designed specially to accommodate a 25-inch cone to be used in service with 66 kV cables.

A.—Flexible Braid Connection. D.—Expansion Chamber.  
B.—Porcelain Insulator. E.—Base.  
C.—Condenser Cone. F.—Brass Wiping Gland.

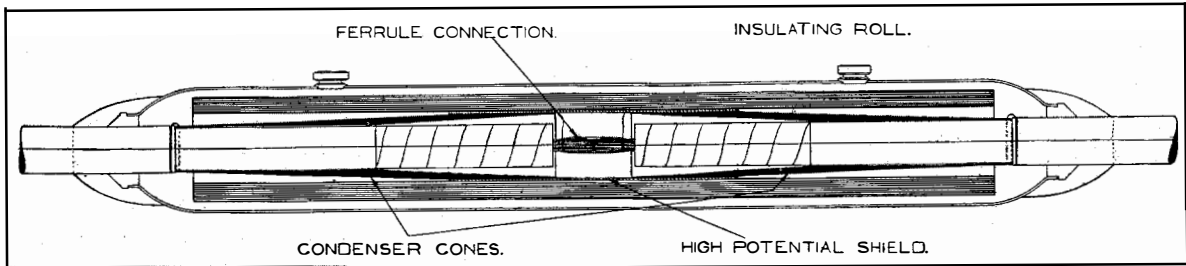

Figure 14—Straight through joint for 66 kV cables employing condenser cones.

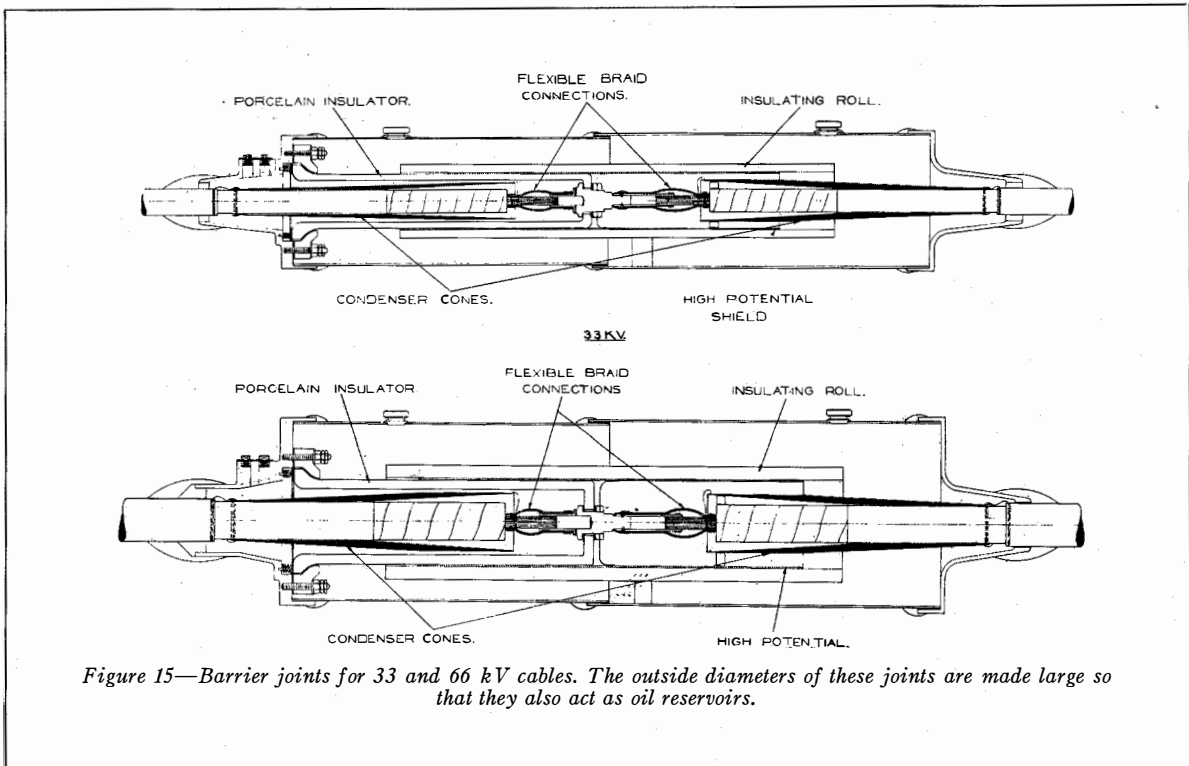

Figure 15—Barrier joints for 33 and 66 kV cables. The outside diameters of these joints are made large so that they also act as oil reservoirs.

demarcation between the cable dielectric and the jointing insulation. It is easy enough to make the radial strength of the added insulation quite sufficient, but breakdown always tends to occur along the tapered surface over which the added insulation is wrapped. As in the case of terminations, this trouble is mainly due to the non-uniformity of the stress distribution and the application of condenser cones provides a means of grading this stress. Their use also makes possible the factory made joint which can be applied in the minimum of time in the field. This is a great advantage since there is not only a great saving of time and cost in jointing the cable, but also the deterioration and absorption of air

and moisture due to the long exposure occasioned by hand lapping is obviated. Figure 14 gives a design for a normal straight through joint for 66 kV cables. In this joint it is unnecessary even to taper the core papers. The procedure is simply to trim the lead sheath, slip on the cones, joint the cores, apply impregnated paper roll, wipe on lead sleeve and, after evacuating, fill with oil.

In the case of barrier joints, the barrier is provided by a porcelain sleeve which encloses a cone. Barrier joints of reasonable dimensions are notoriously difficult to construct, but with the aid of cones results have been obtained which are eminently satisfactory and examples of these

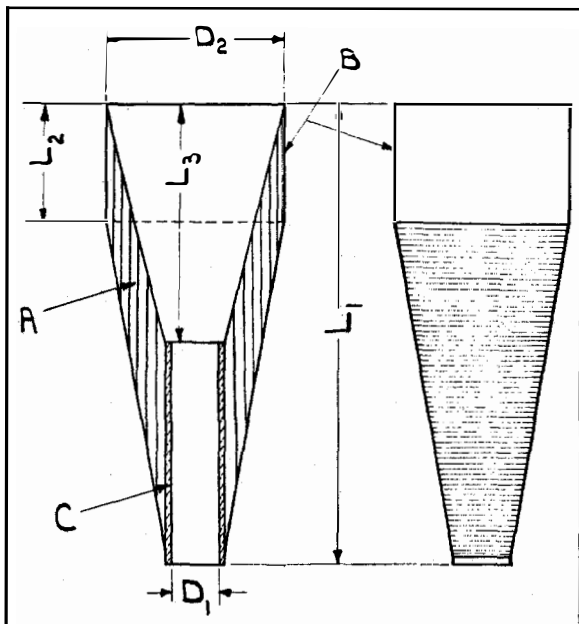

Figure 16—Diagram of Condenser Cone.

- A = Layers of impregnated paper and metal foil.  
 B = Outer metal foil (to have electrical connection with conductor).  
 C = Metal former (to fit over core insulation or lead sheath, and to have electrical connection with the latter).  
 D1 = Internal diameter of metal former.  
 D2 = External diameter of cone.  
 L1 = Overall Length of cone.  
 L2 = Length of outer metallic layer.  
 L3 = Length of inner cone.

joints are now in service. Figure 15 shows barrier joints for 33 and 66 kV cables.

The 33 kV joints have successfully withstood test pressures of 80 kV to earth for 8 hours. On dismantling no sign of deterioration was observed.

**Standardisation of Design.** This has been made possible largely owing to the fact that it is permissible to have a fairly loose fit between the tube of the cone and the cable without substantially reducing its strength. Thus a range of diameters has been standardised from 1.2 to 2.6 inches which increase in increments of 0.2 inch, this being sufficient to cover the entire normal range of cable diameters. Besides the Standard Cones, special cones to suit any particular requirement can be designed and manufactured on request.

Figure 16 shows diagrammatically the dimensional factors involved. The table at end of article gives the main dimensions.

To give a graphical idea of their practical dimension, several standard designs have been

drawn to scale and are reproduced in Figure 17.

**Test Results.** The voltage which an end will withstand depends on so many factors that it is impossible to give complete data on the subject. For a given length of end, the breakdown voltage increases with the dielectric thickness, and cables of large diameter are stronger than those of smaller diameter for the same amount of dielectric. As has been previously mentioned, the use of certain filling materials of high specific inductive capacity such as halowax oil, considerably increases the strength of the cone. Cones which fit tightly over the dielectric are somewhat stronger than those which are fitted over the lead sheath although the difference is slight. Fitting in an end-bell or joint and completely submerging in oil considerably increases the breakdown value, although the characteristics are surprisingly good when tested as normally in the open. In this connection, the cones have proved to be quite robust and will last a considerable time with normal care in handling. They have been exposed for several months to air in the laboratory without suffering appreciable deterioration, and it is hoped in the near future to manufacture them in such a way that exposure to atmosphere will have little or no effect at all on their electrical characteristics.

There is finally the well-known voltage time relationship which is similar to that which holds for cables, but in general the ends have proved stronger than the cable when appropriate cones are used on test. Thus using standard 66 kV cones of length 25.25 inches and internal diameter of 1.4 inches on a 33 kV cable, a test pressure of 95 kV was maintained for many hours on end in air and they survived several breakdowns in various lengths of the cable. A cone slipped over the lead on a similar 33 kV cable with only a 6½ inch test end withstood a test pressure of 110 kV for 5 minutes without breaking down.

Cones terminating 33 kV cables (19 kV to earth) in end-bells have been life tested for over 7 months at 30 kV to earth without giving the slightest trouble, and standard 33 kV cones of length 16½ inches have likewise been successfully tested in conjunction with 66 kV cables as already mentioned.

The 50¼ inch cones have been used in making short time breakdown tests on 33 kV cables and

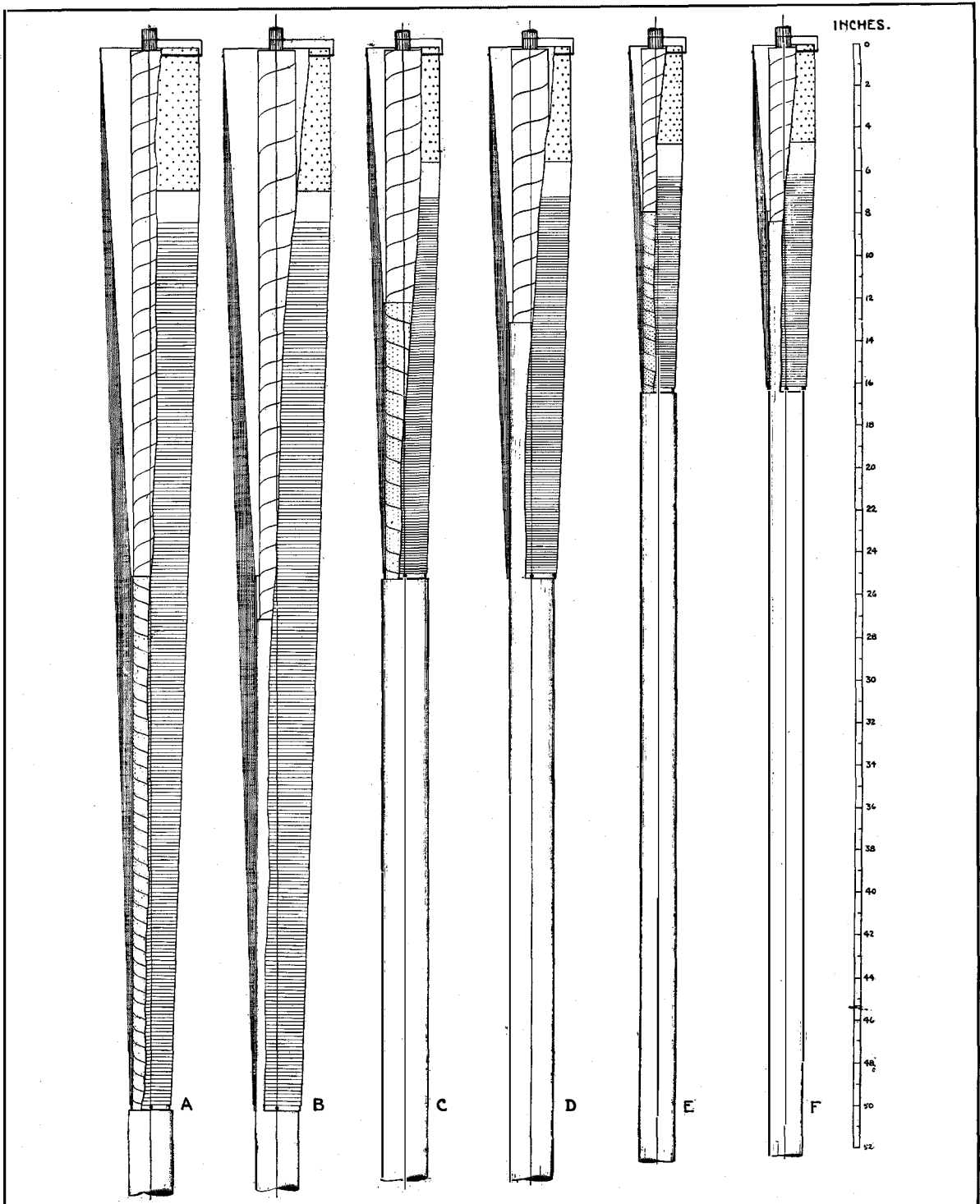

Figure 17—Some standard sizes of cones drawn to scale to illustrate the compact nature of the design.

(A)  $50\frac{1}{4}$  inch Cone over H. paper on 66 kV cable  
 (B)  $50\frac{1}{4}$  inch Cone over Lead on 66 kV cable  
 (C)  $25\frac{1}{4}$  inch Cone over H. paper on 66 kV cable

(D)  $25\frac{1}{4}$  inch Cone over Lead on 66 kV cable  
 (E)  $16\frac{1}{2}$  inch Cone over H. paper on 33 kV cable  
 (F)  $16\frac{1}{2}$  inch Cone over Lead on 33 kV cable

pressures of 190 kV or ten times the working voltage maintained until breakdown occurred in the cable. Used for testing 66 kV cable, pressures up to 300 kV have been maintained upon several occasions with the cones in air until the cable has broken down. In this way valuable data may conveniently be obtained on short samples of cable.

Finally the cost of the cones is relatively slight, and their use will usually result in effecting substantial economies both in development work and general service.

### Bibliography

1. *Elektrische Festigkeitslehre* (Published by Julius Springer, Berlin).

2. British Patent Spec. No. 181,796.
  3. P. Torchio, "132,000-volt Single Conductor Lead Covered Cable Introduction, Economics and Commercial Demand," *Trans. A. I. E. E.*, November, 1927, p. 186.
  4. J. B. Whitehead and F. Hamburger, Jr., "Residual Air and Moisture in Impregnated Paper Insulation—III," *Trans. A. I. E. E.*, December, 1931, vol. 50, p. 1430.
  5. E. A. Beavis, "Some Developments in the Routine Pressure Testing of High Voltage Cables," *Journal I. E. E.*, October, 1928, vol. 66, p. 1086.
  6. F. M. Farmer, "Tests of Paper-Insulated High Tension Cable," *Trans. A. I. E. E.*, May, 1926, vol. 45, p. 553.
  7. R. W. Atkinson and D. M. Simmons, "Oil-Filled Cable and Accessories," *Trans. A. I. E. E.*, December, 1931, vol. 50, p. 1421.
- British Patent Spec. No. 273,641.
- D. M. Simmons, "Present Practise in Insulated Power Cables," *Electrical Engineering*, February, 1932, vol. 51, p. 83.

### DIMENSIONS OF STANDARD CONES

Code No.	Int. Diam. Inner Metal Former		Ext. Diam. of Cone D 2		Length of Cone L 1		Length of Outer Metallic Layer L 2		Length of Inner Cone L 3	
	ins.	cms.	ins.	cms.	ins.	cms.	ins.	cms.	ins.	cms.
4050-A	1.2	3.0	2.22	5.6	16.5	42	4.63	11.8	7.82	19.8
B	1.4	3.6	2.42	6.2	16.5	42	4.63	11.8	7.82	19.8
C	1.6	4.1	2.62	6.6	16.5	42	4.63	11.8	7.82	19.8
D	1.8	4.6	2.82	7.2	16.5	42	4.63	11.8	7.82	19.8
E	2.0	5.1	3.18	8.1	16.5	42	5.64	14.3	8.18	20.8
F	2.2	5.6	3.38	8.6	16.5	42	5.64	14.3	8.18	20.8
G	2.4	6.1	3.58	9.1	16.5	42	5.64	14.3	8.18	20.8
H	2.6	6.6	3.78	9.6	16.5	42	5.64	14.3	8.18	20.8
4051-A	1.2	3.0	2.86	7.3	25.25	64	5.45	13.8	12.13	30.8
B	1.4	3.6	3.06	7.8	25.25	64	5.45	13.8	12.13	30.8
C	1.6	4.1	3.26	8.3	25.25	64	5.45	13.8	12.13	30.8
D	1.8	4.6	3.46	8.8	25.25	64	5.45	13.8	12.13	30.8
E	2.0	5.1	3.66	9.3	25.25	64	5.45	13.8	12.13	30.8
F	2.2	5.6	3.86	9.8	25.25	64	5.45	13.8	12.13	30.8
G	2.4	6.1	4.06	10.3	25.25	64	5.45	13.8	12.13	30.8
H	2.6	6.6	4.26	10.8	25.25	64	5.45	13.8	12.13	30.8
4052-A	1.2	3.0	4.06	10.3	50.25	127.6	6.8	17.3	25.1	63.8
B	1.4	3.6	4.26	10.8	50.25	127.6	6.8	17.3	25.1	63.8
C	1.6	4.1	4.46	11.3	50.25	127.6	6.8	17.3	25.1	63.8
D	1.8	4.6	4.66	11.8	50.25	127.6	6.8	17.3	25.1	63.8
E	2.0	5.1	4.86	12.3	50.25	127.6	6.8	17.3	25.1	63.8
F	2.2	5.6	5.06	12.9	50.25	127.6	6.8	17.3	25.1	63.8
G	2.4	6.1	5.26	13.4	50.25	127.6	6.8	17.3	25.1	63.8
H	2.6	6.6	5.46	13.9	50.25	127.6	6.8	17.3	25.1	63.8

Working Voltage of Cable      Single Phase      Length of lead sheath to be removed:

No. 4050 Type	33 kV	60 kV	(a) If cone is fitted over metallised paper = L1 for all types.
No. 4051 Type	66 kV	110 kV	(b) If cone is fitted over lead sheath = L3 + ½" for 4050 type.
No. 4052 Type	132 kV	220 kV	= L3 + 1" for 4051 type.
			= L3 + 2" for 4052 type.

To determine the correct internal diameter of inner metal former, add .050" to the cable or lead sheath diameters respectively in the case of 4050 and 4051 types, and .100" when 4052 types are required. The nearest standard diameter ABOVE the size thus obtained is that which should be specified.

# Radio Broadcast Receivers

By J. S. JAMMER

*Assistant Vice-President, International Standard Electric Corporation*

and L. M. CLEMENT

*Chief Engineer, Radio Broadcast Receivers*

**P**RACTICALLY all companies in the International System Group are now busily engaged in the exploitation of radio broadcast receivers, designed, manufactured and sold on a coordinated basis in almost all of the countries of the world.

Broadcast receivers are an increasingly important unit of modern radio and differ greatly from the usual forms of commercial radio, since the receivers are scattered in literally millions of homes and the operator usually possesses little or no technical knowledge. Radio sets are, however, closely allied to the usual forms of the communication business, since the sets are manufactured from parts which are similar in many respects to those used in telephone repeaters, carrier, radio transmitters, etc.

While radio receiving sets are related to other communication equipment, the design, manufacture and sale of receiving sets present entirely different problems from other lines of manufacture. Most of the communication systems supplied by the International Group of companies are designed to meet requirements which are fully anticipated and are the result of years of experience with similar equipments. The design work is carried out at a more leisurely pace, manufacture usually has ample time, and the sale is made to comparatively few specialized customers. After completion, the equipment is maintained by experts thoroughly familiar with the technical details of the system.

Receiving sets, on the other hand, are a seasonal business, subject to rapid changes as the public demand varies, and the design, manufacture and sale of the equipment require exceptional team work on the part of the Engineering, Manufacturing and Sales Organizations, in order to keep abreast of the art, maintain a uniform load on the factories, deliver sets when required, and keep distribution organized in such

a way as to avoid the possibility of stocks of obsolete models when styles change.

New designs are constantly being developed by the Central Engineering Department, and the radio engineers must produce models which can be manufactured quickly and cheaply and, at the same time, must be absolutely perfect in their performance and rugged enough to continue to give satisfactory operation under the most severe conditions.

The radio engineers work closely in conjunction with the factories and the purchasing departments, in order that the shop may proceed with tools and the purchasing departments may obtain raw materials in the world's markets at competitive prices without delay. All three of these groups work very closely with the sales organizations, which are responsible for laying down the commercial requirements and forecasting the quantities of various types which will be disposed of at specific times. The whole requires perfect, smooth running and coordinated organization.

Radio receivers are no longer a semi-scientific toy, of interest to a few radio amateurs with some electrical knowledge; the radio set today is a source of entertainment and is purchased for use in the home by individuals whose tastes with regard to artistic design and musical reproduction vary to a considerable extent. In the modern radio set, we are dealing with a combination of furniture, a musical and a scientific instrument.

Because of certain local requirements and the many handicaps which today surround the export business, International Group Companies manufacture radio sets in many of the principal countries of the world. This adds much to the complexity of the problem, for instead of one centralized manufacturing plant it is necessary to set up a number of individual units doing

practically the same job, with just those differences which are dictated by local requirements. It is for this reason that a special and separate radio organization has been formed within the Company, with the administration of radio activities carried out in the field rather than from administrative headquarters. In most of the factories the radio work is separated completely from the other activities with the exception of the punch press department where there is, however, a separate foreman for radio pieces.

The fundamental development of circuit designs and components is carried out by groups of development engineers, one located at London and one at Sydney. These groups issue to the particular factories which make use of the groups' designs, preliminary specifications describing the receivers and, concurrent with the development, supply their factories with day-to-day information on the development as well as manufacturing drawings of completed parts, to enable the factories to get a true picture of the receiver and to tool up for various final components before the design is completed.

Complete working models, manufacturing tracings and specifications are also supplied. The factories, in conjunction with their development group, adapt the fundamental design to meet the special needs of a particular country or to make use of available raw material. The cabinets for each territory are designed locally, so as best to cater to the tastes of the country for which they are intended. In addition to the artistic requirements, considerable attention is paid to cabinet designs, in order that they will be acoustically perfect.

In producing the fundamental designs, painstaking consideration is given to seemingly unimportant details, as experience has shown us that these are often the factors which determine whether or not the sets can be manufactured satisfactorily and economically in large quantities. For example, it will be seen from reference to Figures 1 and 2 that once the sockets and miscellaneous parts are fastened to the chassis, almost all other assembly and wiring operations can be accomplished from the bottom. This feature alone makes it possible to pass the receivers down the assembly line in one position

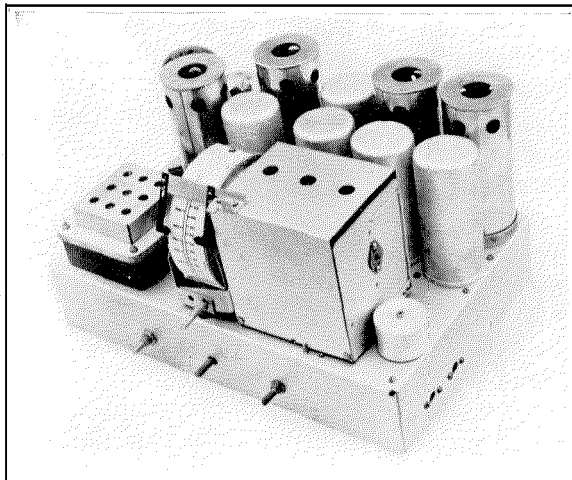

Figure 1—6-Valve Superheterodyne Receiver Chassis (Top View).

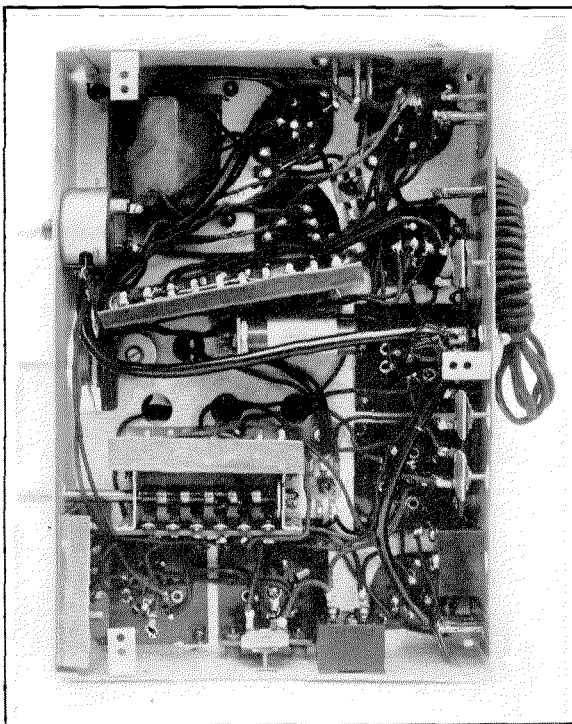

Figure 2—6-Valve Superheterodyne Receiver Chassis (Bottom View).

(bottom up) and makes for easy and economical manufacture.

Insofar as possible, each receiver uses the same coil shield, coil form, trimmer condensers, etc. This lowers the cost of the various parts as larger quantities of each are made. It makes the



tool cost less and enables a new receiver to be designed at little additional expense when the components are available.

Care is taken in the layout and design so that manufacturing processes will be simple, that the use of elaborate tools will not be required, and that the necessary raw materials are such as are available in adequate quantities in the usual markets.

Special attention is given to production control and flow of material so as to eliminate all superfluous handling and to speed up production. Routines are set up so that authorizations pass through and deliveries are made within a period which varies from four to six weeks from the date the Sales Department places orders. Periodic inventories of parts prevent unbalanced stocks building up at the end of the season.

At the present time, companies in the International Group are producing about thirty different models (see Table I) and the sets are being manufactured at Kolster-Brandes in London, Le Matériel Téléphonique in Paris, Bell Telephone Manufacturing Company in Antwerp, United Telephone & Telegraph Works, Limited, in Vienna, Standard Electric Company, Limited, in Budapest, and Standard Telephones & Cables (Australasia) in Sydney. Practically all of the sales companies are handling the products of one or more of these factories, and arrangements for export have been made.

The sales organization for the distribution of sets varies from one country to another, the distribution arrangements having been set up to best meet the needs of each particular country.

In some cases the companies sell direct to the public, in other cases to authorized dealers, to wholesalers, factors or agents. A detailed description of the commercial organization and the reasons for the particular form in each country would be too lengthy to describe in this paper. It is sufficient to say that these local needs have been adequately met.

In order to back up the selling organization, it is essential that a receiving set once sold remains sold, so that the customer is not continually demanding service aid due to faults developing in the field. Particular attention has been paid to the organization of the Service Departments with most satisfactory results. In

addition, considerable engineering study has been given to the question of inspection. All components receive a 100 per cent. inspection. The assembled and wired chassis receives numerous mechanical and electrical inspections throughout its fabrication. The completed chassis, including tubes with which it will be shipped, is measured in the line for sensitivity, and the speaker is given numerous tests to ensure its proper performance. The completed chassis and speaker are mounted in the cabinet, and the complete receiver is given an overall check immediately before packing. Each set is, therefore, adjusted to operate as a complete unit and

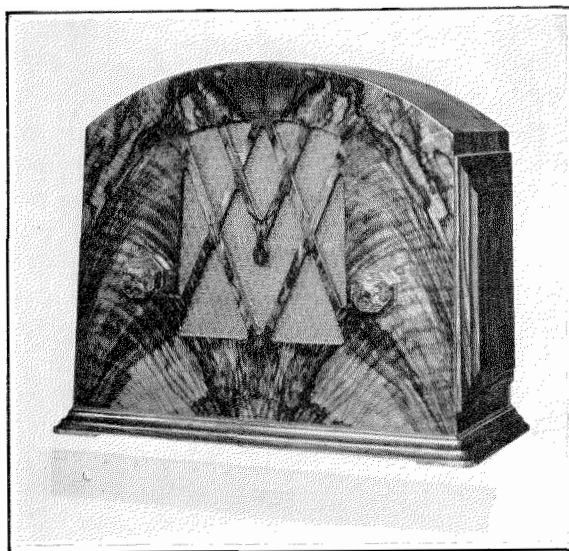

Figure 3—Vienna 4-Valve AC-DC Midget Superheterodyne Receiver.

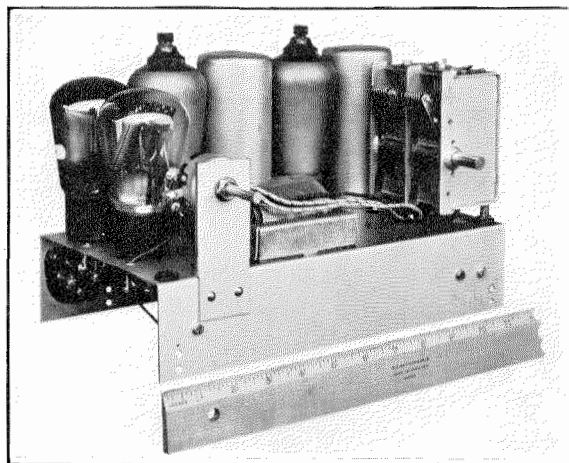

Figure 4—Vienna AC-DC Midget Set (Top View).

TABLE I  
Receivers Produced by the International Group of Companies

Factory	Name or No. Tubes	Type	Wavelength Range	Cabinet	Features
Antwerp	4 (3+1)	Super.	200/600; 800/2000	Table type	"Rejectostat" A.V.C. Tone
Bell Tel. Mfg. Company	6 (5+1)	Super.	200/600; 800/2000	Table type	Comp. Tone Control "Rejectostat"
Budapest	3 (2+1)	Regen. T.R.F.	15/80 { 200/600; 800/2000 }	Table type	{ S.W. Operation "Rejectostat"
Standard Electric	4 (3+1)	Super.		Table type	
Company, Limited	5 (4+1)	Super.	Table type		
	6 (5+1)	Super.	200/600; 800/2000	Table type	
	1	{ Super. S.W. Convertor }	15/80	Table type	
London	K.B. 321	4 (3+1)	Regen. T.R.F.	Table type	{ "Rejectostat" "Rejectostat" A.V.C. Tone Control, Tone Comp. "Rejectostat" A.V.C. Tone Control, Tone Comp. "Rejectostat" A.V.C. Tone Control, Tone Comp., Q.A. V.C. Push- Pull Audio S.W. Operation
Kolster-Brandes,	K.B. 320	5 (4+1)	Regen. T.R.F.	Table type	
Limited	K.B. 354	3	{ Regen. T.R.F. Batt. }	Table type	
	K.B. 333	3	{ Regen. T.R.F. Batt. }	Table type	
	K.B. 337	4	{ Regen. T.R.F. Batt. Portable }	Table type	
	K.B. 444	4 (3+1)	Super.	Table type	
	K.B. 666	6 (5+1)	Super.	Table type	
	K.B. 666	6 (5+1)	{ Super. (De Luxe Model) }	Table type	
	K.B. 888	8 (7+1)	Super.	Console	
	K.B. 357	1	{ Super. S.W. Convertor }	Table type	
London	2	T.R.F. Batt.	200/600; 800/2000	Table type	{ A.V.C. Tone Control, Tone Comp. S.W. Operation
Standard Telephones and Cables, Limited	3 (2+1)	Regen. Det.	200/600; 800/2000	Table type	
	3	Regen. T.R.F.	200/600; 800/2000	Table type	
	4 (3+1)	Super.	200/600; 800/2000	Table type	
	6 (5+1)	Super.	200/600; 800/2000	Table type	
	1	{ Super. S.W. Convertor }	15/80	Table type	
Paris	4 (3+1)	Super.	200/600; 800/2000	Table type	{ "Filtrostat" "Filtrostat," A.V.C. Tone Comp., Tone Control S.W. Operation
Le Matériel Téléphonique, S. A.	6 (5+1)	Super.	200/600; 800/2000	Table type	
	1	{ Super. S.W. Convertor }	15/80	Table type	
Vienna	4 (3+1)	Super.	200/600; 800/2000	Table type	{ "Rejectostat"
United Telephone & Telegraph Works, Limited	4 (3+1)	Super. AC-DC	200/600	Table type	
	1	{ Super. S.W. Convertor }	15/80	Table type	
Sydney	5 (4+1) 8 (7+1)	Super.	200/600	Console type	{ "Rejectostat" "Rejectostat"
Standard Telephones and Cables (Australasia), Ltd.		Super.	200/600	Console type	

to assure a rich, full tone which reproduces with absolute fidelity the entire frequency range required. It is for this reason that Standard sets are acknowledged to be of superior quality by those who have trained and expert musical knowledge. Incidentally, considerable attention has been devoted to the design of the packing crate or carton, as it is a vital factor in the safe transport of the receiver to the customer.

Because of the very large number and high power of the broadcasting stations in Europe, severe selectivity requirements are imposed on the receivers and for this reason practically all of the models are of the superheterodyne type, although some few tuned radio frequency models are being produced for use where special requirements exist. The superheterodyne receivers are available in four, five, six and eight valve models. In addition, there are being made Universal Midget Sets, views of the Vienna A.C. and D.C. Midget Receiver being shown in Figures 3 and 4, as well as better quality Universal Sets known as the Compact Type.

The requirements, of course, vary to some extent with the locality in which the sets are to be sold, and depend upon a number of factors;

for example, whether local broadcasting is more popular than distant reception, whether extremely high power stations are in the immediate neighbourhood, whether the timbre of the language requires an exceptionally wide band of reception, etc. Therefore, in the fundamental design of receivers to be used in all countries, great flexibility must be provided, so that they may be adapted to the requirements of each country.

Three-valve regenerative receivers have been designed for England and Hungary (Figures 5 and 6). The latter are equipped for reception on the short wave range as an additional feature. Due to the fact that the London Empire short wave broadcaster (designed and constructed by Standard Telephones & Cables) is exceptionally well-received in Eastern Europe during the day time, these sets are finding a popular demand in this district.

The demand for short wave reception is by no means universal, and the vast majority of sets are furnished without the incorporation of the short wave feature. However, any of the superheterodyne sets referred to herein can be adapted to operate on short waves if required. This does

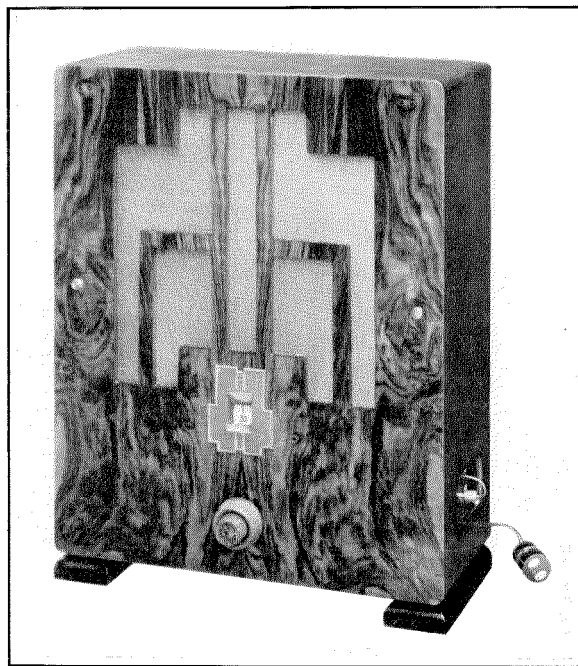

Figure 5—Standard Telephones & Cables, London, 3-Valve Receiver.

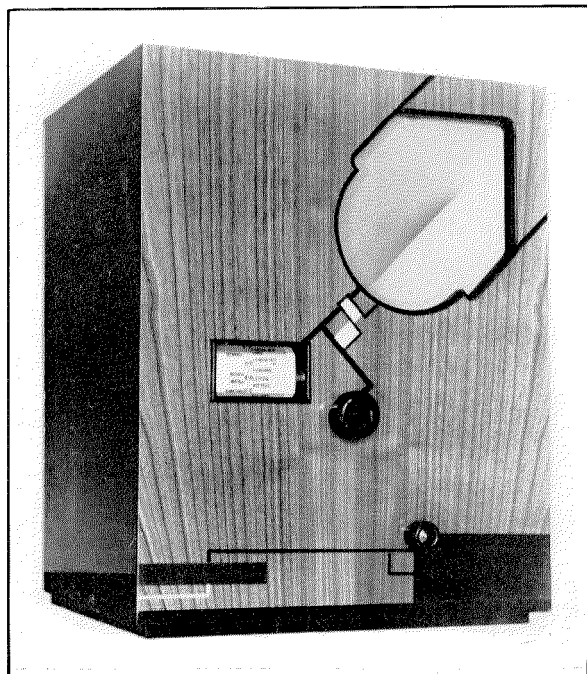

Figure 6—Standard, Budapest, 3-Valve Receiver.

not mean any change is necessary in the set, but simply that, if the customer wishes the set to operate on short waves, a so-called "convertor"

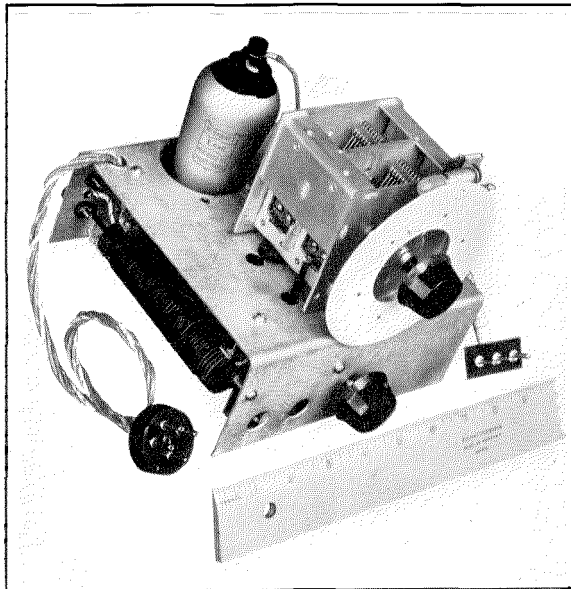

Figure 7—Short Wave Convertor Chassis (Top View).

(Figure 7) can be plugged into the back of the receiver.

In England and Australia there is still a potential market for tuned radio frequency receivers, and models of this type are being marketed. Figure 8 shows a view of the Kolster-Brandes receiver.

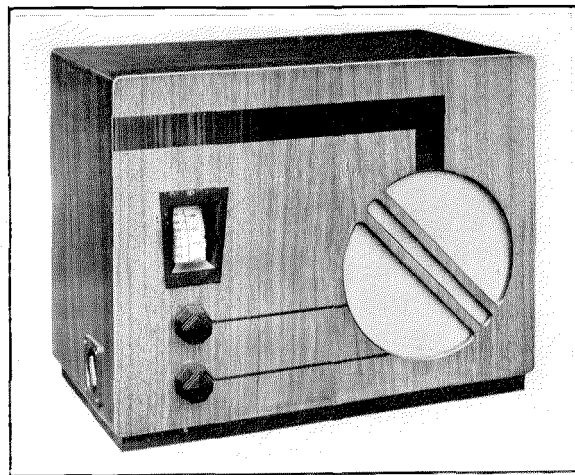

Figure 8—Kolster-Brandes 3-Valve Band Pass Receiver, Battery Operated (KB.333).

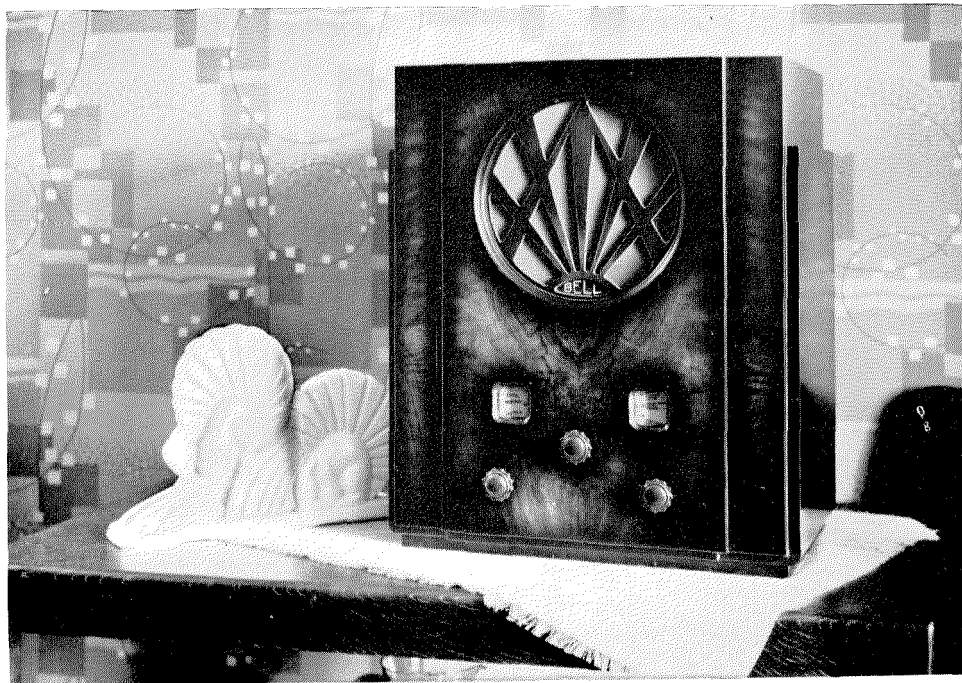

Figure 9—Antwerp (Bell) 4-Valve Superheterodyne Receiver.

London, Antwerp, Paris, Vienna and Budapest are making inexpensive four-valve superheterodyne receivers, some of which are shown in Figures 9 to 12, inclusive. They are substantially built, and designed to give good quality of reproduction at good volume. A circuit schematic is shown in Figure 13.

The five-valve superheterodyne (Figure 14) is being offered by Budapest. This receiver has good selectivity, good quality and is equipped with tone control. This latter feature has been added so that the response characteristics can be adjusted by the listener to suit his taste or his acoustic requirements.

Six-valve superheterodyne receivers are being produced by Kolster-Brandes, Antwerp, Paris and Budapest, and certain of these sets are illustrated in Figures 1, 2, 15 and 16. They use the diode-triode tubes, which allow the use of an excellent system of automatic volume control. Among the features of the six-valve receivers might be mentioned tone control and automatic tone compensation. This latter is interesting. When the volume control of an average radio set is turned down, the listener gets the impression that the lower and higher frequencies are cut off at the low volume. This effect is due to the non-linear sensitivity characteristic of the human ear at the upper and lower frequencies. By arranging a circuit which attenuates the middle frequencies faster than the upper and lower frequencies, and which only becomes operative when the volume control is turned down, the ear then hears the lower and higher frequencies at low volumes in the

same proportion as at louder volumes. This effect is pleasing, and is a feature in both the six- and the eight-valve receivers. The circuit arrangements are shown associated with the

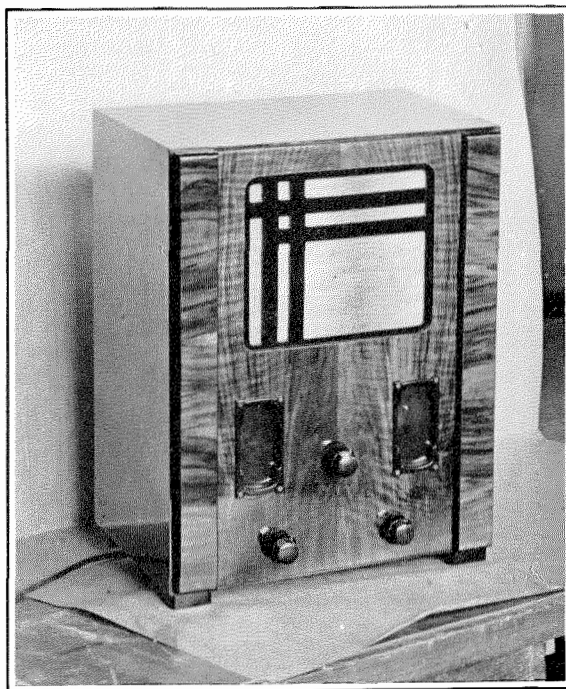

Figure 11—Vienna 4-Valve Superheterodyne Receiver.

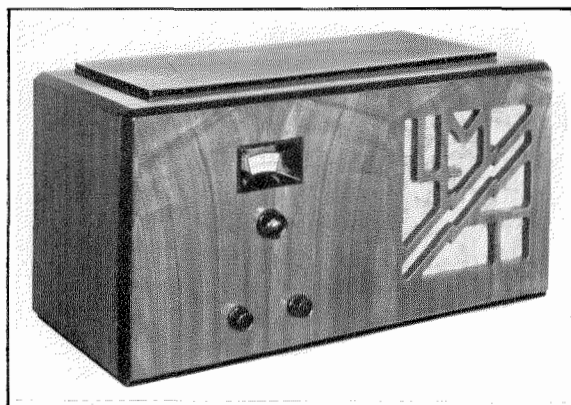

Figure 10—Paris 4-Valve Superheterodyne Receiver.

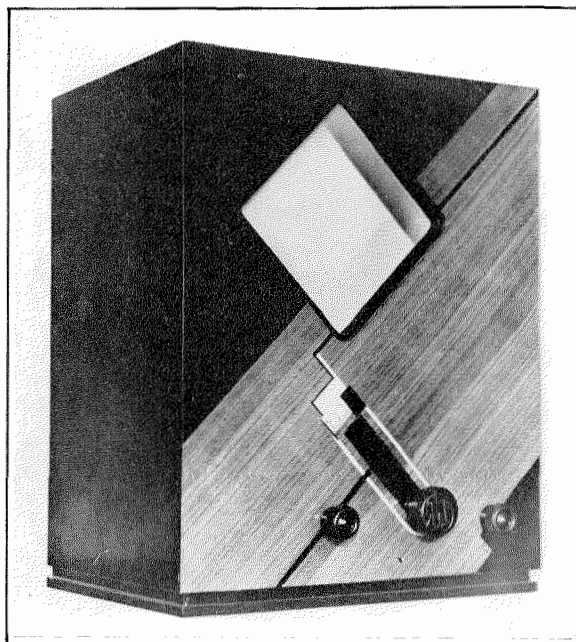

Figure 12—Telefongyar, Budapest, 4-Valve Superheterodyne Receiver.





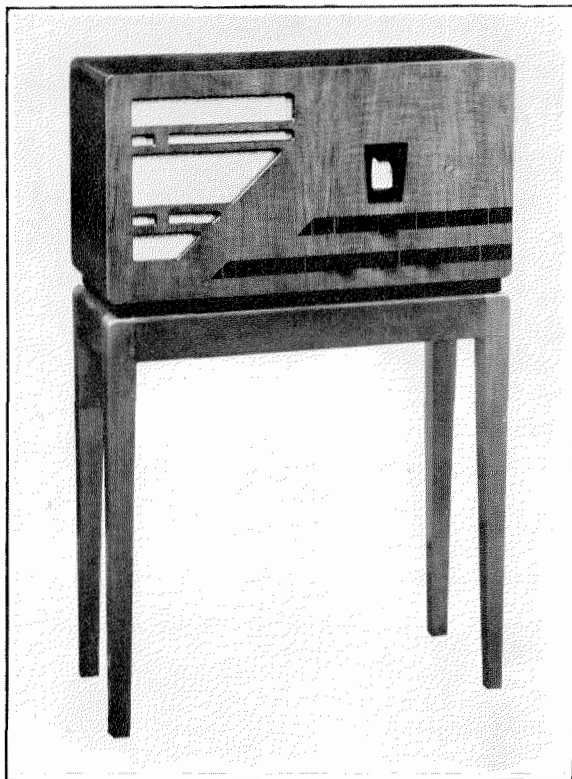

Figure 15—Standard Telephones & Cables, London, 6-Valve Superheterodyne Receiver.

As most of the sets are made to operate on two bands of broadcasting wave lengths, a wave switch is provided for switching from one to the other. In some of the sets the two ranges are shown on the same tuning dial, coloured lights indicating whether the set is operating on the medium or long wave ranges. In other sets, two windows are provided, one or the other being illuminated, depending upon the position of the wave switch. The Vienna four-valve superheterodyne is provided with a so-called "Kino" scale, in which the stations are shown by name by means of a film projected on the window.

We have mentioned that a radio set today is sold for its entertainment value and not merely as a semi-scientific toy. The quality of the programmes transmitted from modern broadcasting stations, such as supplied by Standard Companies, and the fidelity of the reproduction of Standard receivers, are such as to give very high grade transmission of music or speech. The one big difficulty, however, with radio reception up to the present has been the interference caused

by local electrical disturbances, which appear as noise, buzzing, crackling and crashes in the loud-speaker. In some districts this "man-made static" is sufficient to prevent reception of radio programmes. Fortunately, through the use of the so-called "Rejectostat"\* ("Filtrostat"\* in France), which companies in the International Group are now manufacturing and furnishing in conjunction with their radio sets, this annoying interference has been practically eliminated, thus removing a great obstacle from the path of the real function of a radio set, that is, to provide entertainment.

The elimination of so-called "man-made static" is accomplished by locating the receiving antenna outside the range of interference and conducting the antenna energy to a completely screened receiver by means of a carefully screened low impedance transmission line. The transmission line consists of a pair of conductors in an electrical shield, and is of a relatively low impedance. This low impedance transmission is matched to the high impedance antenna circuit and the high impedance receiver input by means of shielded high frequency transformers (see Figure 19).

\* Registered Trade Marks.

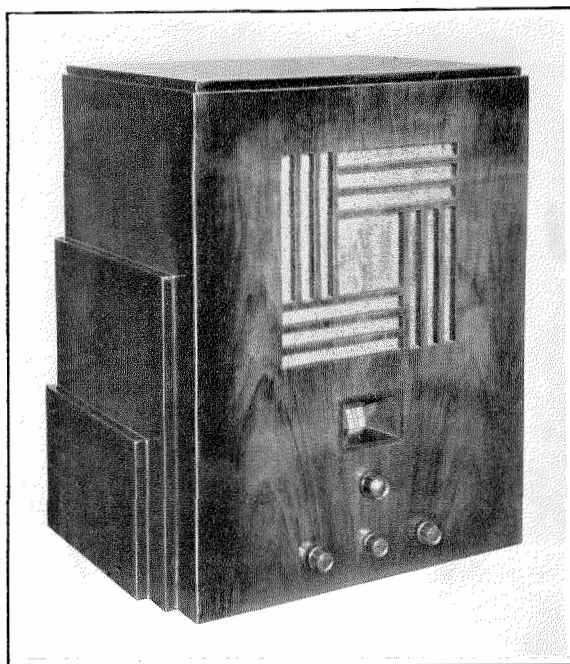

Figure 16—Paris 6-Valve Superheterodyne Radiogramophone.

As European radio receivers operate over a band of 200 to 2000 metres, the Rejectostat must also operate efficiently over this wave range. One of the major problems in the design of these Rejectostat transformers was to maintain effi-

ciency of transmission over this wide range. Most of the interference energy from a local electrical disturbance is closely confined to the vicinity of its source, and consequently a remotely-located antenna will not pick up appre-

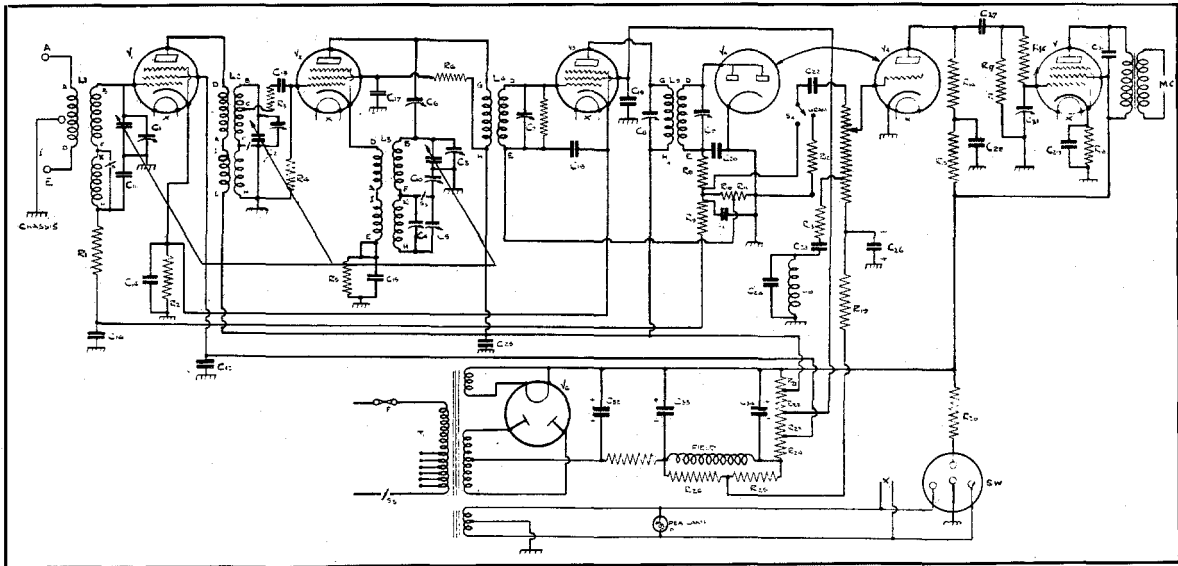

Figure 17—Schematic Diagram of 6-Valve Superheterodyne Receiver.

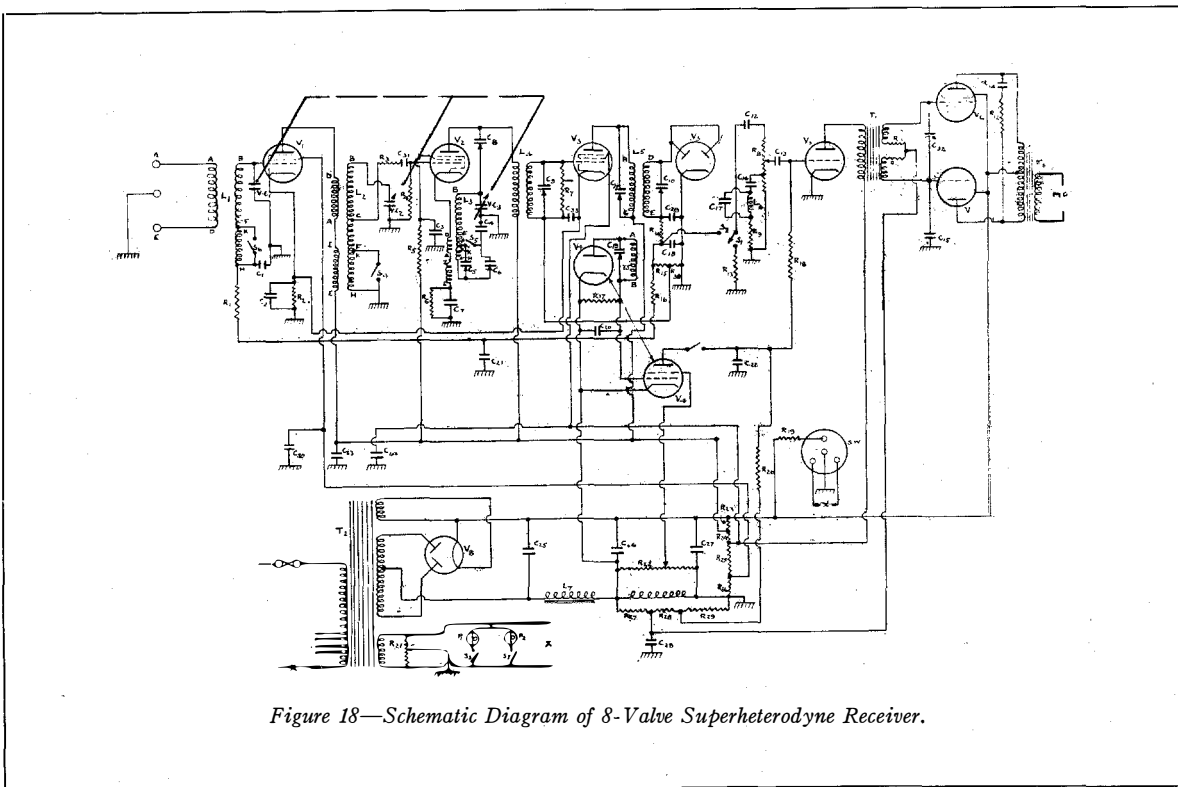

Figure 18—Schematic Diagram of 8-Valve Superheterodyne Receiver.



ciable interference. Because of the low impedance of the transmission line, the losses in this circuit are small. Thus, it is possible to locate the antenna as far as 1000 feet from the receiver without appreciable loss in signal strength. This freedom in regard to location of the antenna, which heretofore had been severely limited with conventional antenna and lead-in, makes it relatively simple to locate the antenna in an interference-free area. In the majority of installations, however, a simple roof-top antenna is completely satisfactory when attached to a "Rejectostat" transmission system.

The completely screened receiver to which the shielded transmission line is connected has been carefully designed to reject all interference that might be introduced via the power mains or other sources. Great care has been taken to make the shielding very complete and effective, and the receiver wiring has been carefully planned so that only the wanted signal energy

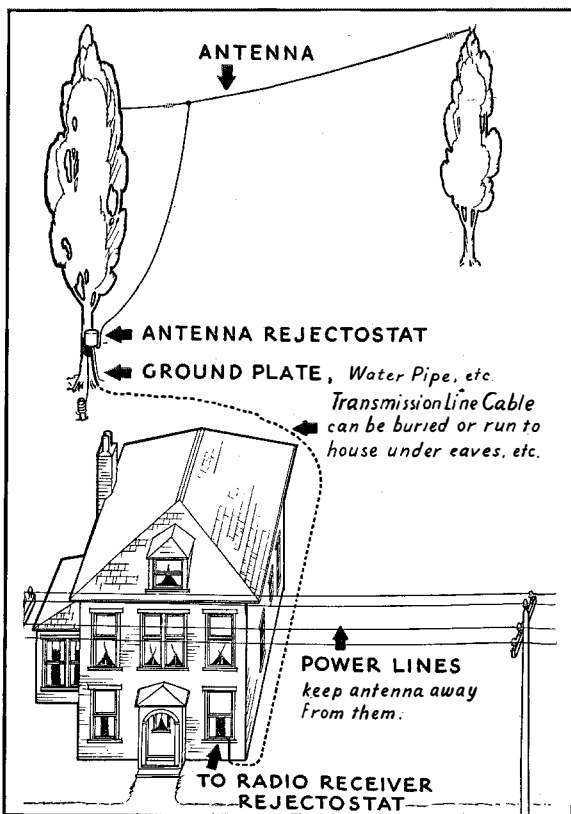

Figure 19—Typical "Rejectostat" Installation.

reaches the amplifiers. In the installation, all the screening is carefully grounded to low impedance grounds, to prevent re-radiating interference to the antenna.

The "Rejectostat" is finding wide fields of application in centralized radio installations,

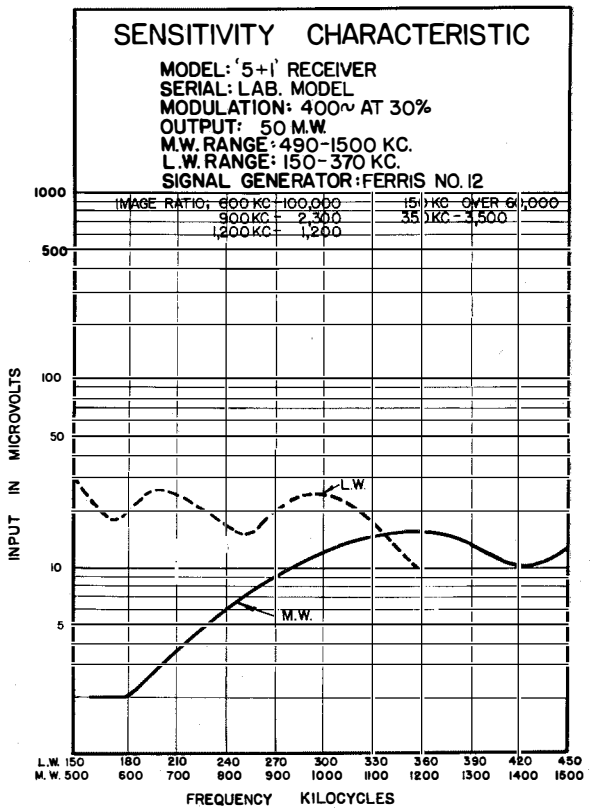

Figure 20—Sensitivity Characteristic of 6-Valve Superheterodyne Receiver.

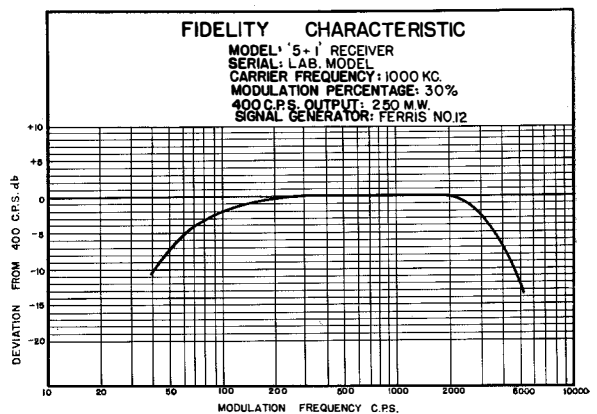

Figure 21—Fidelity Characteristic of 6-Valve Superheterodyne Receiver.

TABLE II

Micromesh Radio Receiving Set Valves developed and being furnished by Standard Telephones and Cables, Ltd.

Type	Use
5B1	Detector H.F. Amplifier
HLB1	Detector L.F. Amplifier
PB1	Power Output
PenB1	Power Pentode
SGA1	Detector H.F. Amplifier
VSGA1	Vari-Mu
HLA1	Detector L.F. Amplifier
HLA2	Detector L.F. Amplifier
11A2	Double Diode Triode
9A1	Vari-Mu H.F. Pentode
8A1	H. F. Pentode
PA1	Power Output
PenA1	Power Pentode
7A2	Power Pentode

radio-diffusion systems, and marine installations, in addition to its usefulness to individual broadcast reception. It has also attracted considerable attention and commendation from Government agencies studying radio interference problems.

Since the valve is the heart of the radio set, considerable attention has been given to the design and manufacture of modern valves, and Standard Telephones and Cables, Limited (London) now manufactures and sells a complete line of radio receiving valves suitable for all purposes under the trade mark of "Micromesh." These valves are designed and manufactured in Standard's valve factory, which has been specially equipped for this purpose. The company brings to the manufacture of these domestic radio receiving valves eleven years of experience in the manufacture of valves for radio transmission and reception, telephone repeater work

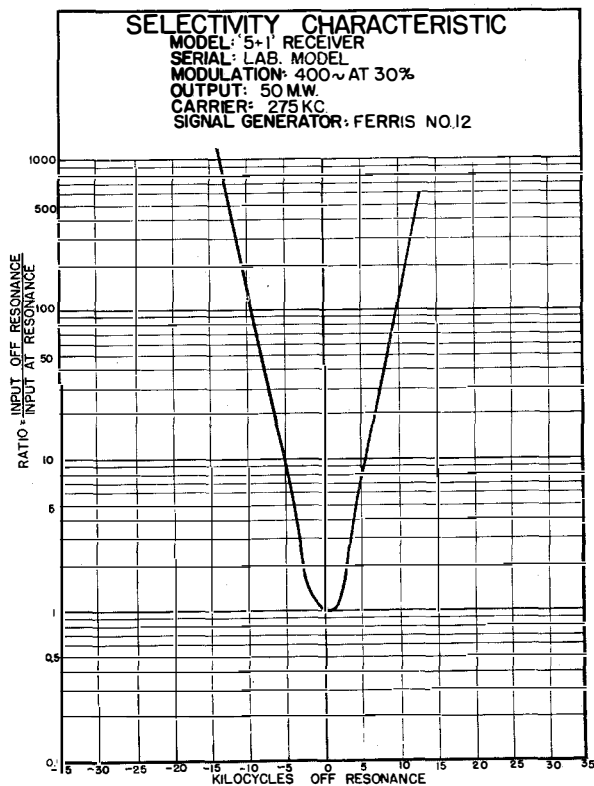

Figure 22—Selectivity Characteristic of 6-Valve Superheterodyne Receiver.

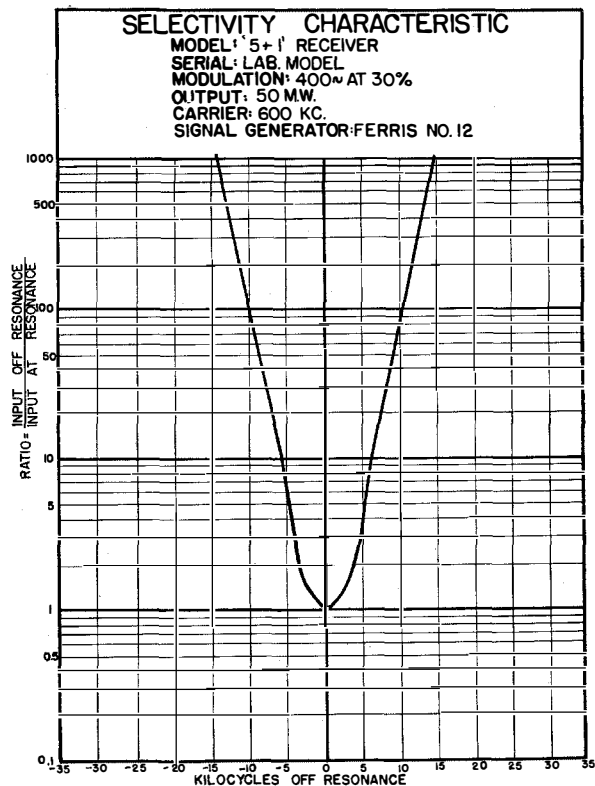

Figure 23—Selectivity Characteristic of 6-Valve Superheterodyne Receiver.

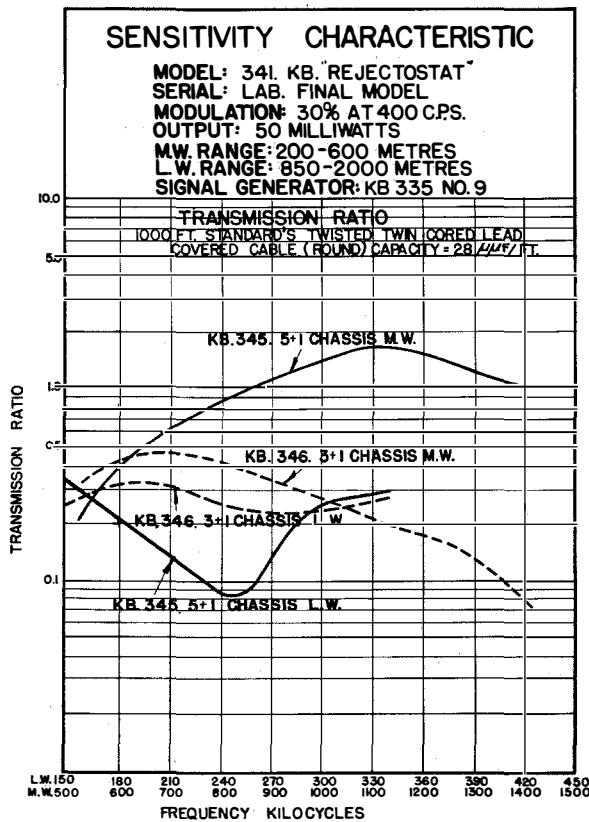

Figure 24—Rejectostat Characteristic.

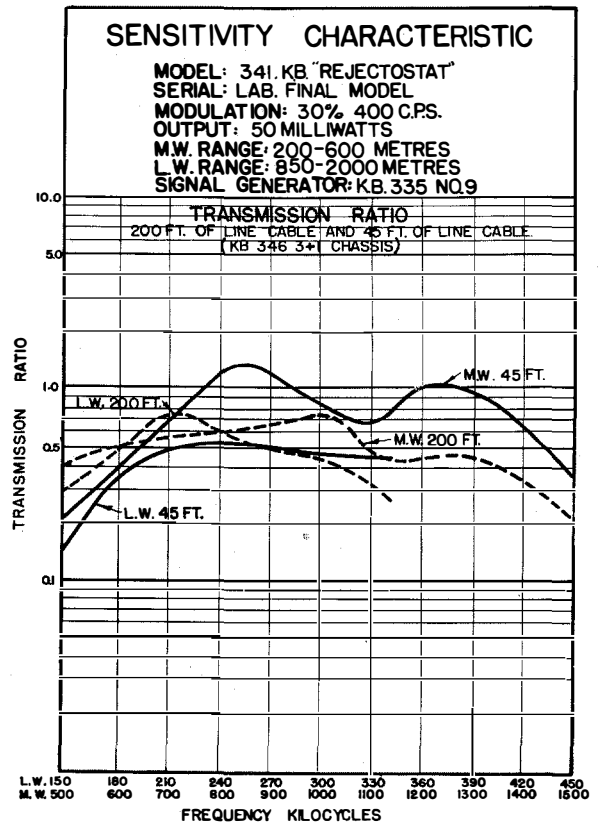

Figure 25—Rejectostat Characteristic.

and other special valves requiring exceptional high quality, which has been the characteristic of Standard valves throughout the World.

The plant is equipped with the latest type of machinery and elaborate testing equipment for making life tests and other special tests on the various products of the factory. It is equipped with a special development laboratory, in which new designs are tried out and tested before being put into manufacture and is staffed by a very efficient personnel, many of whom have had long

experience in the manufacture of the older lines of Standard valve products.

The various types of "Micromesh" valves and their use are listed in Table II.

An indication of the high quality and other favorable characteristics of the radio broadcast receivers described above may be gleaned from Figures 20 to 23 inclusive, which show the characteristics of the six-valve superheterodyne sets. Figures 24 and 25 give the sensitivity characteristics for the Rejectostat.

# The Variation of Overall Attenuation with Current Strength in a Telephone Circuit Loaded with Coils Having Non-Linear Characteristics

By K. E. LATIMER, B.Sc.

*Standard Telephones and Cables, Limited*

**SUMMARY:** *Formulae are given by which, when the attenuation per unit length is a quadratic function of current, it is possible to calculate the overall attenuation of a line for various current strengths rigorously or, alternatively, to estimate in a simple way the limits between which the correct value lies. Certain discrepancies in other published formulae are pointed out.*

*The importance of using the correct attenuation formula rather than an approximate one, is stressed, even in cases where the approximate formula gives a tolerably correct value of attenuation.*

*It is pointed out that when the hysteresis attenuation is measured by a device which reads the voltage or current ratio rather than the power ratio, it is necessary to make an impedance correction which is comparable with the hysteresis attenuation.*

*The results of calculations and measurements are in substantial agreement.*

## Introduction

IN connection with a laboratory investigation of assymmetric distortion, an artificial coil-loaded line was constructed in order that measurements might be made of the various effects due to loading coil hysteresis, among them the amount by which the attenuation of the line varied with change of current or "hysteresis attenuation."<sup>1</sup>

The hysteresis attenuation measured was quite small, in the order of .005 néper per milliamperere under the worst conditions. The value, however, could not be made to agree with calculations using the hitherto published formulae which are collected for reference in the Appendix and, moreover, discrepancies existed between the various results of calculation. The derivations of the known formulae were examined critically, therefore, and in several respects it was found that assumptions which differed rather widely from the truth had been made and in one case an actual error was discovered.

It eventually developed that the difficulty was not due entirely to imperfect calculations, but to another effect which will be explained. As a result, calculations and measurements were brought into reasonable agreement.

<sup>1</sup> The change of attenuation considered is principally due to hysteresis but is also caused by variations of permeability. The two effects are interrelated. The term "hysteresis attenuation" is used to include both.

It is proposed to discuss the difficulties which arise from using the existing formulae, and to explain the various refinements which it appears necessary to make in the present methods of calculation in the light of the experience so far obtained.

## Limitations of Existing Formulae

In all existing work it is assumed that the line current is sinusoidal, and that the impedance of the line does not vary from point to point to such an extent as to render invalid the attenuation formulae derived from a consideration of lines with invariable "prime constants." One is rather apt to take these apparently straightforward assumptions for granted or even to forget that they are assumptions; however, when it is a question of measuring hysteresis attenuation, the following two interesting points arise:

- (a) That the presence of small harmonics in the tone may make an appreciable difference in the hysteresis attenuation.
- (b) That some of the difficulty of reconciling calculations with measurements arises from the assumption made with regard to the impedance, as will be seen later.

## Meyer's Formula<sup>2</sup>

Meyer's formula is based upon the assumption that the attenuation per unit length at any point

<sup>2</sup> *Elektrische Nachrichten-Technik*, vol. 3, p. 33.

in a circuit can be calculated from the formula:

$$\beta = \frac{R_o + rJ}{2} \cdot \sqrt{\frac{C}{L_o(1+\lambda J)}} + \frac{G}{2} \sqrt{\frac{L_o(1+\lambda J)}{C}} \quad (1)$$

where:

$\beta$  is the required attenuation per unit length.<sup>3</sup>

$R_o$ ,  $L_o$ ,  $C$  and  $G$  are the prime constants for zero current.

$r$  and  $\lambda$  are constants associated with hysteresis.

$J$  is the R.M.S. current at the given point. In the case of a coil loaded line  $J$  will be defined as the current at mid-load.

In order that this assumption may be justifiable for purposes of calculating hysteresis attenuation, two conditions must be fulfilled, namely,

- $\beta$  must be given with reasonable accuracy by formula (1).
- The relative contribution of the various parts of the circuit to the attenuation must be correctly expressed by formula (1).

In practice it is often found that simple hysteresis attenuation formulae which are not restricted by these conditions will give much more accurate results than the Meyer formula in spite of the apparent refinement of the latter. This is particularly the case with coil-loaded circuits, which usually fulfill the first condition fairly well, but not the second. Caution must be used also in cases where the resistance is comparable with the reactance, and on Krarup loaded circuits with appreciable eddy current losses.

Apart from these disabilities, the Meyer formula has much to recommend it, and is particularly valuable on submarine cable circuits. The formula as published breaks down at low frequencies, but may easily be extended as shown in the appendix.

#### Deutschmann's Formula<sup>4</sup>

The present discussion is scarcely concerned with this formula, as it was evolved with a view to simplicity rather than accuracy, so that it is rather unfair to criticize it from the latter standpoint.

<sup>3</sup> A complete list of symbols will be found in the appendix.

<sup>4</sup> *Elektrische Nachrichten-Technik*, vol. 6, p. 80.

Briefly, change of inductance is neglected, and, as Doebke points out, it is apt to break down badly on lines having appreciable hysteresis effects. In addition, the attenuation formula assumed, which is approximately correct if the line resistance can be considered concentrated at the load points, is so far from the truth on actual cable circuits that it is more accurate to neglect lumpiness effects altogether.

#### Doebke's Formula<sup>5</sup>

Doebke deals with the problem by first making the assumption that the attenuation per unit length can be expressed by the formula:

$$\beta = \beta_o + H_1 J + H_2 J^2 \quad (2)$$

where  $\beta_o$ ,  $H_1$  and  $H_2$  are constants.

This is a sounder foundation than that on which Meyer's work is based, but the expression for the hysteresis attenuation which was finally evolved by Doebke is not so satisfactory. The formula in question is:

$$b_h = \log \left[ \frac{\beta_a}{\beta_o} \right] + \log \left[ \frac{H_1}{H_1 + H_2 J_a} \right] \quad (3)$$

where  $b_h$  is the hysteresis attenuation, while the subscript "a" indicates the conditions at the beginning of the line. While this formula is plausible if  $H_2$  is zero, it is difficult to believe that it is correct under all conditions. As will be seen later, the second term on the right side of the equation may easily have the values  $+\infty$  or  $-\infty$  or may be imaginary. In any case according to the formula  $H_2$  has quite an appreciable effect even when the conditions do not approach a discontinuity.

#### Development of Hysteresis Attenuation Formulae

From the above it will be seen that there are several unsatisfactory features connected with the theory of the subject, so that a short consideration of the problem from this point of view would not be out of place.

It is proposed to show that formula (3) is satisfactory for most practical purposes if  $H_2$

<sup>5</sup> *Elektrische Nachrichten-Technik*, vol. 8, p. 340. Note that Doebke uses the opposite convention for the sign of  $H_2$  in the formula given below. This does not affect the argument.

is neglected. Further, a method of determining the error arising from this procedure is given, and formulae corresponding to (3) are provided for cases in which the error is found too great.

As a starting point equation (2) will be assumed. Further, in the case of a coil-loaded line, the attenuation per loading section will be assumed small, so that Meyer's differential equation may be used:

$$dx = \frac{dJ}{\beta J} \tag{4}$$

where  $x$  represents distance from the sending end.

A sinusoidal current is also assumed, and for the moment the impedance variation assumption used in all the previous work will be accepted.

Combining (2) and (4):

$$dx = \frac{dJ}{\beta_0 J + H_1 J^2 + H_2 J^3} \tag{5}$$

A digression will now be made in order to explain the physical significance of (5).

Suppose  $H_1$  and  $H_2$  are both assumed to be zero, so that hysteresis effects are neglected. Integrating, the following result is obtained:

$$l = \frac{1}{\beta_0} \log \left[ \frac{J_a}{J_e} \right] \tag{6}$$

where  $l$  is the length of the circuit and the subscript "e" represents conditions at the receiving end.

This familiar expression is illustrated by Figure 1. Curve (a) is a graph of:

$$f(J) = \frac{1}{\beta_0 J} \tag{7}$$

where  $f(J)$  signifies "function of current." The area under the curve between the ordinates  $J_a$  and  $J_e$  is, from (5) and (6), the length of the circuit, so that if this and  $J_a$  are fixed,  $J_e$  can be determined.

Curves (b), (c) and (d) represent respectively:

$$f(J) = \frac{1}{\beta_0 J + H_1 J^2} \tag{8}$$

$$f(J) = \frac{1}{\beta_0 J + H_1 J^2 + H_2 J^3} \tag{9}$$

$$f(J) = \frac{1}{\beta_0 J + (H_1 + H_2 J_a) J^2} \tag{10}$$

Curve (c) thus corresponds to the general equation (5), while (a), (b) and (d) are special cases of curve, (c) involving various assumptions with regard to  $H_1$  and  $H_2$ .

The areas under all these curves between  $J_a$  and  $J_e$  must be the length of the circuit, so that three separate values of  $J_e$  are thus determined.

Now curve (c) lies entirely between curves (b) and (d) for all values of current below  $J_a$ . Therefore, the value of  $J_e$  (and hence the hysteresis attenuation) corresponding to curve (c) must also lie between those corresponding to (b) and (d).

This fact is rather useful as the hysteresis attenuation corresponding to curves (b) and (d) may be calculated much more easily than that corresponding to (c). Further it will be shown by numerical examples that the Doebke formula does not always give results within the assigned limits, so that it may be concluded that there must be an error in Doebke's work.

To proceed once more from equation (5), it will be seen that the next step is to perform the integration so as to arrive at the result analogous to (6). This can be done by the method of resolving into partial fractions. In order to simplify the final result the following relations are introduced:

$$b_h = \log \frac{J_a}{J_e} - \beta_0 l \tag{11}$$

$$A = \sqrt{\frac{4 \beta_0 H_2}{H_1^2} - 1} \tag{12}$$

The validity of (11) will be discussed later. In (12) it is to be understood that  $A$  is to be taken as a real number whether the quantity inside the modulus signs is positive or negative.

Another simplifying assumption is that  $J_e$  is small, although this is optional. The following are the resulting expressions:

$$b_h = \frac{1}{2} \log \left[ \frac{\beta_a}{\beta_0} \right] + \frac{1}{A} \tan^{-1} \left[ \frac{A J_a}{\frac{2\beta_0}{H_1} + J_a} \right] \tag{13a}$$

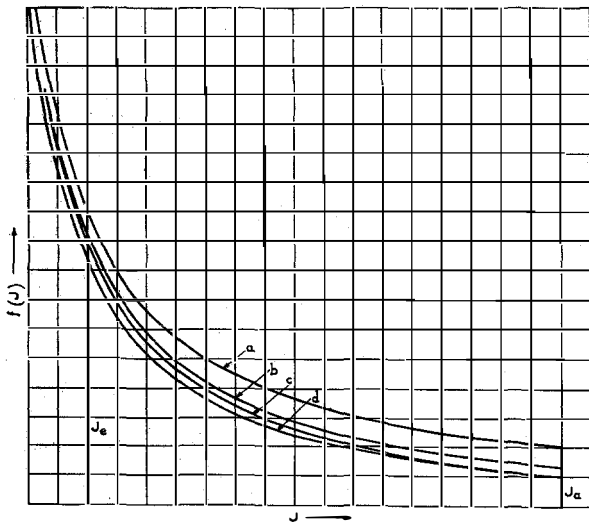

Figure 1

that the true value of  $b_h$  must lie between the values calculated from (14a) and (14b). The information obtained from these two equations will in nearly all cases enable equations (13a), (13b) and (13c) to be dispensed with.

**Determination of Coefficients  $H_1$  and  $H_2$**

The importance of using the correct attenuation formula when calculating  $H_1$  and  $H_2$  has already been pointed out. The actual calculation may be carried out either by the well-known method of expansion by MacLaurin's series, or by the rather quicker "direct method." In the latter case  $\beta$  is computed directly from the attenuation formula with a calculating machine for any three values of current. From the results so obtained, the coefficients may be separated by very simple operations which need not be explained here.

It is generally found that  $H_1$  is positive at the high frequencies and negative at the low frequencies, while the reverse is true of  $H_2$  which usually changes sign at a rather higher frequency than  $H_1$ .

The approximate value of  $H_1$  for a coil-loaded circuit of the extra-light type is:

$$b_h = \frac{1}{2} \left( 1 + \frac{1}{A} \right) \log \left[ \frac{\beta_a}{\beta_o} \right] - \frac{1}{A} \log \left[ \frac{H_2 J_a + \frac{H_1}{2} (1+A)}{\frac{H_1}{2} (1+A)} \right] \quad (13b)$$

$$b_h = \frac{1}{2} \log \left[ \frac{\beta_a}{\beta_o} \right] + \frac{\sqrt{\beta_a} - \sqrt{\beta_o}}{\sqrt{\beta_a}} \quad (13c)$$

Equation (13a) applies when the quantity within the modulus signs in (12) is positive, (13b) when it is negative, and (13c) when it is zero.  $\beta_a$  is the value of  $\beta$  corresponding to a current  $J_a$  from equation (2).

From (13b), when  $H_2$  is zero, the following simple expression results:

$$b_h = \log \left[ \frac{\beta_o + H_1 J_a}{\beta_o} \right] \quad (14a)$$

This is the value of  $b_h$  corresponding to curve (b) in Figure 1.

If  $H_2$  is still regarded as zero in the sense that the variation of  $\beta$  with current is linear rather than quadratic, but instead of  $H_1$  the expression  $(H_1 + H_2 J_a)$  is substituted, the following equation results:

$$b_h = \log \left[ \frac{\beta_o + H_1 J_a + H_2 J_a^2}{\beta_o} \right] \quad (14b)$$

This corresponds to curve (d) in Figure 1. From what has already been proved, it is clear

$$H_1 = \sqrt{\frac{C}{L_o}} \left( \frac{r}{2\sqrt{1-W^2}} - \frac{\lambda R_L}{4} \right) \quad (15)$$

where  $W$  is the ratio of the frequency considered to the cut-off frequency, and  $R_L$  is the line resistance (assumed uniformly distributed throughout the loading section).

Usually the effective value of  $H_1$  is  $\frac{1}{\sqrt{1-W^2}}$

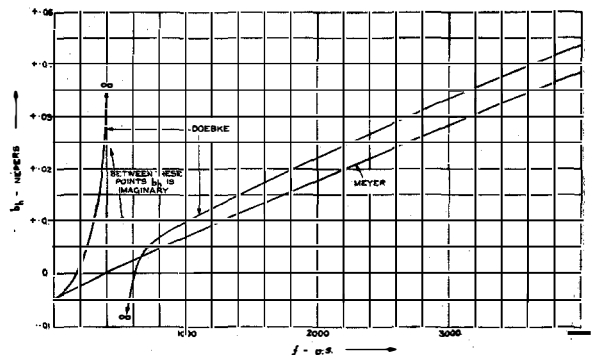

Figure 2

times greater than the above as the current is measured at mid-section rather than mid-load.

**Numerical Examples**

It is now proposed to give some idea of the accuracy obtainable with the various formulae.

*Example 1*

The example given in the Meyer article will now be considered. It will be assumed that  $\beta$  can be calculated with sufficient accuracy from formula (1). The following are the constants given by Meyer:

- $\lambda = 1.33$  per ampere
- $r = 16$  ohms/km. x ampere
- $C = 0.27 \mu\text{F}/\text{km.}$
- $G = 1.62 \mu\text{F mhos}/\text{km.}$
- $L_o = 0.30$  mH/km.
- $R_o = 1.4$  ohms/km.
- $J_a = .080$  ampere
- Frequency not specified
- Line assumed infinitely long

From the above,  $\beta_o = .002370$  népers/km.,  $H_1 = +.02278$  népers/km. ampere and  $H_2 = .01466$  népers/km. ampere<sup>2</sup>.

The following are the results obtained from the various formulae:

Formula	Value of $b_h$ - népers
Meyer (exact).....	.5617
Deutschmann (for coil-loading).....	.914
Doebke's quadratic formula.....	.6004
Formula (13b).....	.5612
Formula (14a).....	.5703
Formula (14b).....	.5477

It will be seen that the Doebke formula is considerably outside the limits given by formulae (14a) and (14b). Formula (13b) gives very good agreement with the Meyer formula, which in this case can be considered to give the true value of  $b_h$ . The results obtained from formulae (14a) and (14b) are, however, good enough for most practical purposes. The reason for the bad results from the Deutschmann formula does not lie in the fact that it was intended for coil-loaded circuits, for the frequency has not been specified, and at low frequencies coil-loading formulae should become identical with smooth line formulae. The trouble is that the Deutschmann formula breaks down on lines having a high hysteresis attenuation.

*Example 2*

The case of the artificial line on which experiments were made will now be considered. The method of construction was such that the resistance of the circuit can be considered con-

centrated at the loading points, so that in this respect the line cannot be said to approximate a cable circuit.

The following constants were assumed:

- $C = .066 \mu\text{F}$  per section
- $L_o = .044$  mH per section
- $\lambda = .001065$  per mA per coil
- $J_a = 10$  mA at mid-load
- $l = \infty$

Freq.	$R_o$ Ohms per Section	$r$ Ohms per mA x Section	G/C Mhos/farad
200	104.26	.0250	5
400	104.35	.0500	10
600	104.54	.0750	15
800	104.71	.1000	20
1000	104.88	.1250	25
1500	105.32	.1875	37.5
2000	105.81	.2500	50
2500	106.30	.3125	62.5
3000	106.82	.3750	75
3500	107.48	.4375	87.5
4000	108.15	.5000	100

In order that a comparison might be made with the Meyer formula it was first assumed that equation (1) was applicable, as in the preceding example. The following results were obtained:

Freq.	$b_h$ in Népers for 10 mA Sending Current			
	Meyer Formula	Formulae (13a) and (13b)	Formula (14a)	Formula (14b)
200	-.002914	-.002901	-.002916	-.002886
400	-.000516	-.000502	-.000511	-.000494
600	.001855	.001870	.001868	.001872
800	.004204	.004220	.004224	.004215
1000	.006532	.006547	.006557	.006536
1500	.01225	.01226	.01229	.01224
2000	.01782	.01784	.01788	.01779
2500	.02326	.02327	.02332	.02321
3000	.02855	.02856	.02863	.02849
3500	.03366	.03368	.03376	.03360
4000	.03864	.03866	.03875	.03856

The results obtained by the Doebke quadratic formula are shown in Figure 2 together with those from the Meyer formula.

From the above it will be seen that, as in the first example, formulae (13a), (13b), (14a) and (14b) give substantially the same results as the Meyer formula, and that the value of  $b_h$  from (13a) or (13b) lies between those obtained from (14a) and (14b). The Doebke quadratic formula, on the other hand, gives a discontinuous curve which is obviously incorrect. The Deutschmann formula gives a value .0462 néper at 4000 p: s.



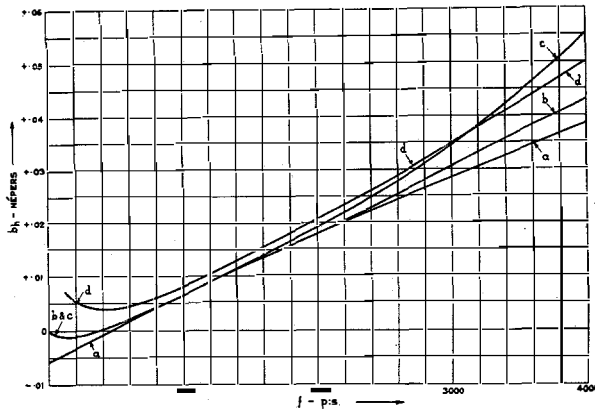

Figure 3

The effects of the coil-loading will now be taken into account. Referring to Figure 3, curve (b) shows the result of substituting the true value of  $H_1$  in formula (14a) or (14b) in place of that derived from formula (1). The effect can be seen by comparison with curve (a) which is reproduced from Figure 2. (In computing the true value of  $H_1$  at the lower frequencies, the fact that  $R_o$  is comparable with  $\omega L_o$  has been allowed for.) Curve (c) gives the corresponding value of  $b_h$  for a cable circuit having the same nominal constants as the artificial line, the difference between the curves (b) and (c) being due to the different distribution of line resistance and the different effect produced by the change of cut-off frequency with current.

From the above it will be seen that contrary to the impression which might be given by casual use of the Doebke quadratic formula,  $H_2$  is in most cases negligible (a fact which has also been verified when the lumpiness of the loading is taken into account). It is much more important by comparison to obtain a reliable value of  $H_1$  than to waste time on a consideration of  $H_2$ .

**Results of Measurements**

In order to obtain sufficient sensitivity, a null method of measuring attenuation was chosen for the tests. A potentiometer was placed across the sending end of the circuit, and a fraction of the sending end voltage was balanced against the voltage received at the far end with the circuit smoothly terminated. The results are shown in Figure 3 by curve (d) which is comparable with the calculated curve (b).

It will be seen that there is a discrepancy between the calculated and measured results, which is greater than the experimental error. This is largely due to the fact that the measurements were made on a voltage basis, and therefore impedance variations with current play a much more important part than under normal operating conditions.

**Impedance Effects**

If the sending end impedance changes with current, the only rational definition for the hysteresis attenuation would be the difference between the circuit loss measured with sending current  $J_a$  and that measured with zero current, both readings being taken with a transmission measuring set having approximately the correct impedance. Expressed as an equation:

$$\begin{aligned}
 b_h &= \log \left[ \frac{J_a}{J_e} \right] + \frac{1}{2} \log \frac{Z_a}{Z_o} - \beta_o l \\
 &= \log \left[ \frac{V_a}{V_e} \right] - \frac{1}{2} \log \frac{Z_a}{Z_o} - \beta_o l \quad (16)
 \end{aligned}$$

where  $V_a/V_e$  is the voltage ratio measured, and  $Z_a$  and  $Z_o$  are the sending end impedances for currents  $J_a$  and zero.

This conflicts with equations (4) and (11), but shows that a correction must be deducted from the readings, when the potentiometer method is used. Allowing for change of cut-off frequency this correction for a coil-loaded circuit terminating in mid-section is:

$$\frac{\lambda J}{4(1-W^2)} \quad (17)$$

By putting  $W=0$  the correction becomes that for a homogeneous line. (17) requires that  $\beta$  be small compared with the phase constant, for then  $Z_a$  may be calculated by substituting  $L_o (1-\lambda J_a)$  for  $L_o$  in the impedance formula.

It will be seen that this correction practically removes the discrepancy, except for a very small amount at the extreme ends of the frequency scale. This residual error possibly may be accounted for by change of eddy current loss with current, and by the fact that the method of phase adjustment is liable to affect the accuracy at the lower frequencies, particularly

when using a rheostat and condenser box to terminate the circuit. Harmonics in the tone also affect the results.

It remains to be considered whether the equations give the correct value of  $b_h$  when the impedance changes with current. It is well known that the reflection loss when two circuits of almost equal impedance are joined together is a second order effect of the impedance difference. The inference is, therefore, that when the sending end impedance is increased by the current passing through the circuit, the line will act rather like a transformer, so that the current at the far end will be greater and the voltage less, by an amount of  $\frac{1}{2} \log Z_a/Z_o$  népers, as compared with what would be expected if the impedance were constant.

Therefore, as a first approximation, the equations give the correct value of  $b_h$ , as defined in (16). Seeing, however, that the current passing through the circuit is greater than when constant impedance is assumed, the equations will, as a second order effect, give a slightly optimistic value of  $b_h$ . If any doubt is felt on this point in extreme cases, it is better to calculate with a sending current greater than that given, by an amount of  $\frac{1}{2} \log Z_a/Z_o$  népers.

**Appendix**

The following are the formulae developed by Meyer, Deutschmann and Doebke, for ease of reference.

**Meyer Formula**

$$b_h = a \log \left[ \frac{R_a C + G L_a}{R_e C + G L_e} \right] + 2 \log \left[ \frac{\sqrt{L_a} + \sqrt{L_o}}{\sqrt{L_e} + \sqrt{L_o}} \right] - 2a \log \left[ \frac{\sqrt{L_a} + a \sqrt{L_o}}{\sqrt{L_e} + a \sqrt{L_o}} \right]$$

where

$$R_a = R_o + r J_a \quad L_a = L_o (1 + \lambda J_a)$$

$$R_e = R_o + r J_e \quad L_e = L_o (1 + \lambda J_e)$$

$$a = \sqrt{\frac{r - R_o \lambda}{r + \frac{G L_o \lambda}{C}}}$$

Other symbols are the same as in the present article. When  $r < R_o \lambda$  this formula may be extended as follows:

$$b_h = 2 \log \frac{\sqrt{L_a} + \sqrt{L_o}}{\sqrt{L_e} + \sqrt{L_o}} - 2b \tan^{-1} \left[ \frac{b \sqrt{L_o} (\sqrt{L_a} - \sqrt{L_e})}{b^2 L_o + \sqrt{L_a} \sqrt{L_e}} \right]$$

where:

$$b = \sqrt{\frac{R_o \lambda - r}{r + \frac{G L_o \lambda}{C}}}$$

**Deutschmann Formula**

$$b_h = \frac{r J_a}{R_o}$$

**Doebke Formula**

$$b_h = \log \left[ \frac{\beta_a}{\beta_o} \right] + \log \left[ \frac{H_1}{H_1 + H_2 J_a} \right]$$

Doebke uses the opposite convention for the sign  $H_2$ , so that the published formula has a minus sign in the denominator of the second term.

**General List of Symbols**

The symbols used by Meyer and Doebke have been followed where possible. The following is a complete list of the symbols used:

$\beta$	Attenuation per unit length	$J_a$	Value of J at beginning of line
$\beta_a$	Attenuation per unit length for current $J_a$	$J_e$	Value of J at end of line
$\beta_o$	Attenuation per unit length for zero current	$rJ$	Increase of resistance per unit length due to hysteresis, for current J
$R_o$	Resistance per unit length of homogeneous line for zero current	$L_o \lambda J$	Increase of inductance per unit length due to change of permeability, for current J
$R_a$	Resistance per unit length of homogeneous line for current $J_a$	$H_1 H_2$	See formula (2)
$R_e$	Resistance per unit length of homogeneous line for current $J_e$	$b_h$	Hysteresis attenuation in népers
$L_o$	Inductance per unit length for zero current	$x$	Distance from sending end
$L_a$	Inductance per unit length for current $J_a$	$l$	Total length of circuit
$L_e$	Inductance per unit length for current $J_e$	$f()$	Function of
$C$	Capacity per unit length	$A$	See equation (12)
$G$	Leakance per unit length	$W$	Ratio of frequency considered to cut-off frequency
$R_L$	Line resistance per unit length of coil-loaded line	$Z_a$	Sending end impedance for current $J_a$
$J$	R. M. S. current (at mid-load for a coil-loaded line)	$Z_o$	Sending end impedance for zero current
		$V_a$	Voltage at sending end
		$V_e$	Voltage at receiving end

# The Rural Telephone Situation in Hungary

By S. LEDECZY

*Technical Director of the Hungarian Postal Administration*

**H**UNGARY, in common with many other countries having scattered rural communities, has suffered from the criticism that the service given at the small rural telephone exchanges does not satisfy the real purpose of the telephone, viz., that in case of necessity it should always be at the disposal of the user. The service at many of the rural exchanges in Hungary is available only between the hours of 8 to 12 a.m. and 2 and 6 p.m. and, owing to the low calling rate, the extension of these hours of service, if only to cover the daylight period, would involve such high costs as to seriously affect the economical working of even the comparatively large networks.

The problem, as in most other countries, is entirely one of cost and, as is generally agreed, cannot be satisfactorily solved by manually operated equipment. Hungary, as an agricultural country with a large proportion of its population dispersed in small villages and communities distant from urban areas, has regarded the provision of a reliable telephone service of real national importance to the social and commercial life of these small communities.

## *Situation in Hungary*

Apart from the restricted service in Hungary, other troubles have been experienced largely as a result of the limited credit facilities. When additional exchanges have been connected to the existing network it has not always been possible to provide junction lines to the next larger main exchange, but to branch these new exchanges on to existing junction lines. The result has been that for a large number of small exchanges the only possible way of getting connection to the main exchange is by transiting many small intermediate exchanges. Such an arrangement obviously is bound to adversely affect the transmission; in fact over distances even as low as 80 kilometres it is hardly possible for the parties to hear each other.



*Mr. S. Ledeczy, Technical Director of the Hungarian Postal Administration.*

It will thus be seen that the two principal problems are the extension of the hours of service and improvement in transmission characteristics, the latter necessitating the replacement of the existing obsolete equipment.

It was considered that the system selected should satisfy the following principal conditions:

1. Continuous day and night service.
2. Improved transmission.
3. Reliability of operation.
4. First cost and maintenance should be on an economical level.

At the outset it was realized that (1) could not be economically provided by manual equipment and that an automatic or semi-automatic system would have to be installed to economically meet the conditions outlined above.

Following the study of the toll and rural traffic it was decided that the question of automation should, for the time being, not be applied to the country as a whole but only to the district exchanges surrounding the main centres.

The toll traffic between these main centres is not sufficient to justify the installation and maintenance cost of direct junctions but, since Budapest has satisfactory direct lines at present carrying relatively low traffic to all the main centres, all traffic between main centres could be routed via Budapest.

In the existing network there are several district exchanges having low traffic and geographically near to the main centres carrying heavier traffic and also dealing with the toll traffic of the area. When considering, therefore, the reformation of the national network to provide continuous day and night service, special regard had to be taken of this circumstance which led to the decision to operate for the time being all the main centre exchanges on a manual basis and the district exchanges on an automatic or semi-automatic basis.

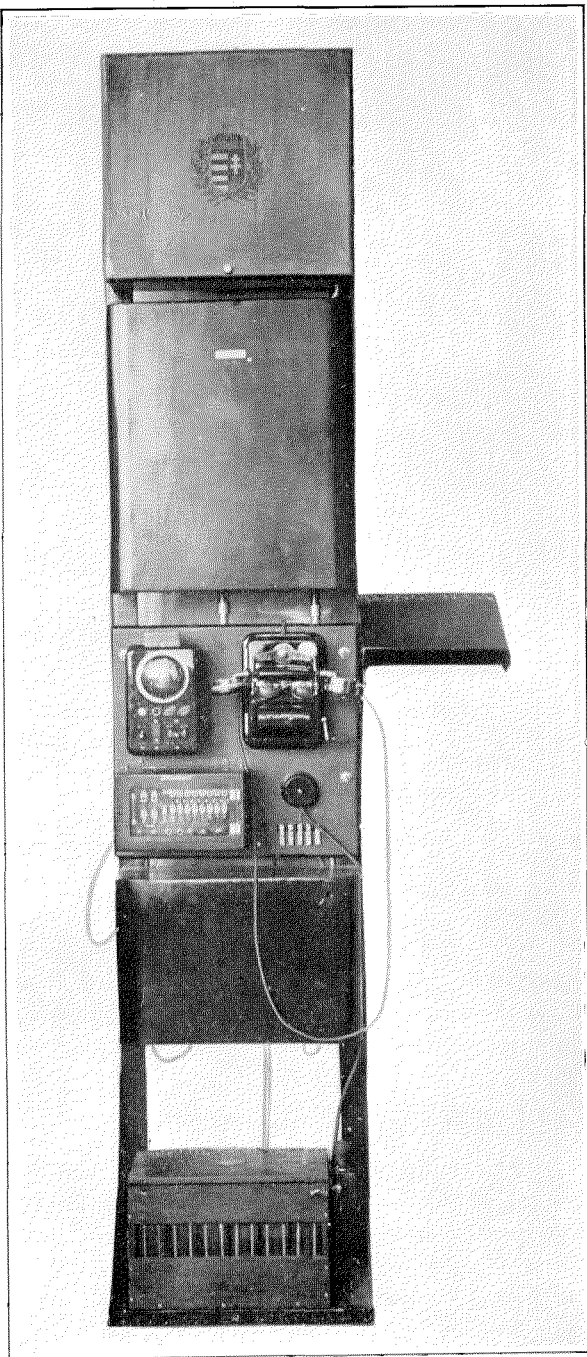

Figure 1—10 Line Semi-Automatic Rural Exchange.

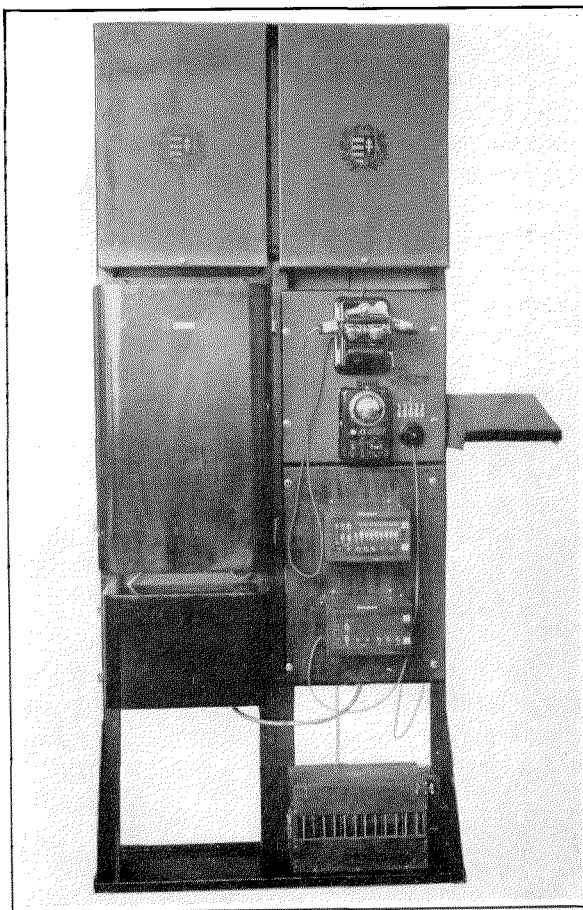

Figure 2—20 Line Semi-Automatic Rural Exchange.

This brings us to the point where a decision has to be made whether to install full automatic or semi-automatic equipment.

The advantages of the full automatic equipment are that the subscriber is able to dial a local call and also in certain cases a toll call, without the intervention of an operator. The disadvantages are that the exchange equipment is more expensive and also that the existing magneto subscribers sets would need to be superseded by dial sets.

The advantage of the semi-automatic systems is that the exchange equipments are cheaper, no message registers are required, and in addition the existing magneto subscribers sets with small modifications could be used.

In the semi-automatic system the junction and toll connections are manually effected by the operator at the main centre exchange. This means that the attendance which is distributed at the present time over a number of small exchanges would be concentrated at the larger main centre.

There are in Hungary 1,046 exchanges where the number of subscribers is less than 100 and 900 exchanges where the number of subscribers is less than 20, representing 82.4% of the total telephone equipment. With the present flat rate tariff the subscribers in the rural districts make an average of one local call a day, which it is estimated would be reduced to 0.5 local calls if metering were introduced.

It will be seen, therefore, that it is not worth while to provide these small exchanges with full automatic equipment since:

- A. The local traffic is so low as not to warrant installation of automatic equipment.
- B. The calls to the main centre could not be made quicker by means of full automatic equipment except by the installation of additional junction circuits.

After careful study of all the factors involved it was finally decided that for the time being, at any rate, the expense of a full automatic system in the rural districts was not justified.

### *Waiting Time*

The following are the maximum "waiting times" which it was decided to establish tentatively for the various classes of traffic.

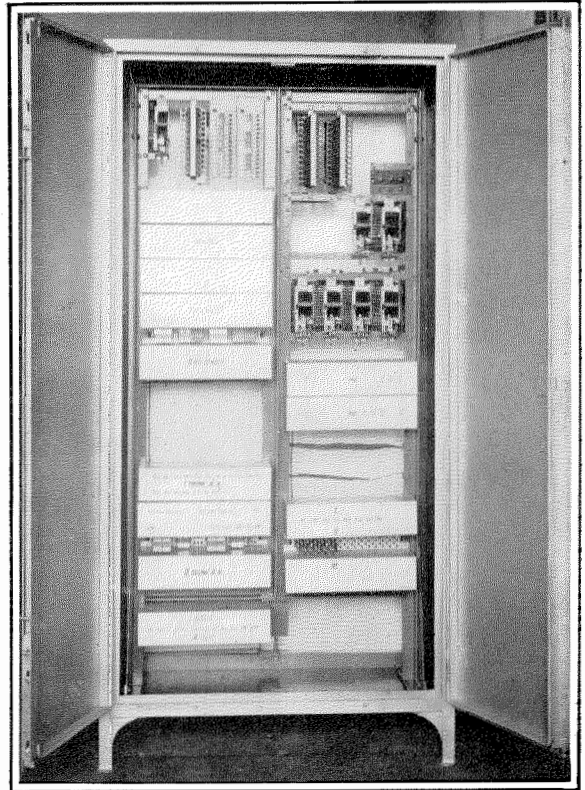

Figure 3—25-50 Line Semi-Automatic Rural Exchange.

1. Local traffic.....	2 mins.
2. Toll ".....	1 "
3. Recording traffic.....	1 "
4. Holding time for toll connection.....	6 "
5. " " " recording.....	1 "
6. Time required for establishing a local connection.....	1 "
7. Ratio day to busy hour traffic.....	20%

The results obtained in practice have been found to be considerably better than those given in the above table, in fact outside the busy hours the waiting time is practically nil.

### *Equipment in the Rural Exchanges*

After examining the features of the various systems that of the Standard Electric Company, Budapest, was selected as being the most suitable. Figure 1 illustrates a 10-line semi-automatic exchange complete with line fuses, relay unit, test sets, control apparatus for supervising service from the public booth, power plant and battery, mounted on a bay 230 cm. high by

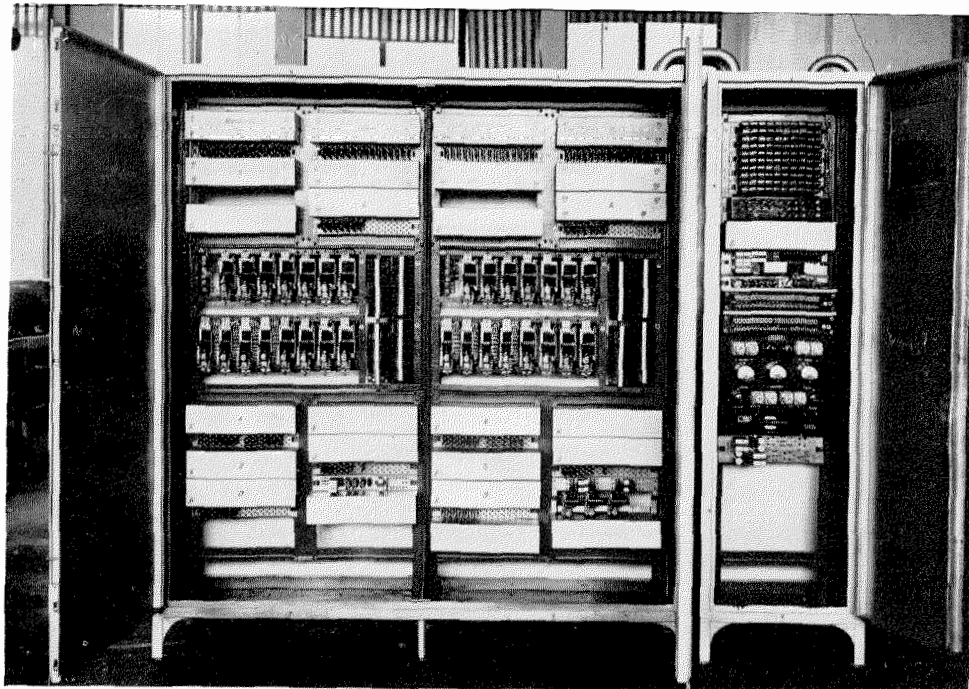

Figure 4—100 Line Full Automatic Rural Exchange.

47 cm. wide. The power plant consists of a metal rectifier which charges a battery of 12 lead cells. Alarm of blown fuses is given locally and in addition is signalled to the main centre.

Figure 2 illustrates a 20-line semi-automatic rural exchange, the features of which are the same as for the 10-line. Figure 3 illustrates a 25-50-line semi-automatic rural exchange, 200 cm. high by 90 cm. wide.

A 100-line full automatic exchange is illustrated in Figure 4 which consists of two 50-line units.

A careful record was made of the faults in the exchange equipment following the cut-over and in the last months of the trial period the actual number of faults was about one per three months

per exchange. It is interesting to note that there were:

1 exchange having no faults during					2 months	
1	"	"	"	"	3	successive months
2	"	"	"	"	4	"
2	"	"	"	"	5	"
1	"	"	"	"	7	"
4	"	"	"	"	8	"
1	"	"	"	"	9	"
2	"	"	"	"	10	"
1	"	"	"	"	22	"

Another interesting fact is that with the improved services at the exchanges cut over, the traffic increased by about 25% and the number of subscribers by about 10%, notwithstanding the fact that in other parts of the country there was a decreasing tendency during the same period.

# The 7-A.2 Rotary Automatic Telephone System

By L. SCHREIBER and W. HATTON

*Les Laboratoires, Le Matériel Téléphonique.*

## PART III

**SUMMARY:** *Part I, which was published in the April, 1933 issue of ELECTRICAL COMMUNICATION, described the new apparatus and equipment. Part II, published in the July issue, described the switching system, junction diagram and floor plan, and the present paper covers the circuit fundamentals and new operating facilities. No attempt is made to describe the detailed operation of the circuits, but rather to convey a picture of the principal features and, where necessary, to give the working limits of lines, junctions and dial speed. Some of the features described are used in the more recent installations of the 7-A.1 Rotary System, and they are mentioned here to preserve the continuity of the description. All circuits are designed for 48-volt operation with a permissible variation of 44 to 52 volts. Figure 1 shows a simplified block key sheet, which should be read in conjunction with the junction diagram shown in Part II.*

### **Subscriber's Line and Line Finder Circuit**

**A**S the title indicates, this circuit provides the apparatus directly associated with the line, the line relay, cut-off relay and message register. It is arranged for single lines, P.B.X. lines and coin collector lines.

**Working Limits.** The maximum external subscriber's loop, including telephone, shall be 1,400 ohms.

For 50-G and 7-J coin collectors, the maximum external loop resistance, including telephone and without ground potential at the coin collector, shall be 820 ohms. With ground potential at the coin collector, the permissible loop resistance will be reduced.

The minimum insulation resistance of the line shall be 10,000 ohms.

As in the 7-A.1 System, special groups of P.B.X. final selectors are not required. P.B.X. groups are indicated by connecting a resistance across the winding of the cut-off relay of the first and last lines. In the event of the first line being busy, the first resistance acts as a signalling means to the final selector that P.B.X. hunting should commence, and the last resistance stops the hunting.

The line circuit is arranged to function with a false call and malicious call finder, which is mounted on the same bay and multiplied with the line finders. It is also arranged for signalling

restricted service to the registers, which is accomplished over the metering brush of the line finder.

### **First Group Selector Circuit**

The circuit includes a group selector, a sequence switch and eight relays.

**Control of Line Finder.** A test relay in the normal position of the sequence switch controls an associated line finder, or one connected via a second line finder, and stops it on a calling line. If two line finders stop on the same line at the same time, a helping relay ensures that only one of the first group selector circuits shall continue to handle the call.

**Continuity Check on "a," "b" and "c" Wires.** Having obtained connection with a calling line, a check is then made to ensure that the circuits of the "a," "b" and "c" wires therefrom are completely established and, if so, the sequence switch moves to the next position and signals a register link circuit to become attached. If the "a," "b" or "c" wire circuits are not completed, the sequence switch does not move and a timing means releases the connection, and the call, if it persists, will be taken by another first group selector.

**Calling for Register Link and Register.** The register link circuit hunts for an idle register and, when found, extends it to the first group selector,



whose sequence switch then moves to the next position, where the calling line becomes extended to the register.

*Reception of Dial Impulses and Setting of Trip Spindle.* After the register has received the dial impulses from the calling subscriber, it signals the sequence switch of the first group selector to advance to the next position, where the register controls the trip spindle of the first group selector, and thereby chooses one of ten sets of brushes associated with ten levels of arc terminals connected to the next selecting stage.

*Hunting for Idle Trunk.* The register then signals the first group selector sequence switch to advance to the next position; the brush carriage of the first group selector then rotates, and trips the chosen set of brushes which hunt over the terminals in the level for an idle trunk.

Means are provided whereby, if required, the hunt for an idle trunk will continue from a chosen level to the next level if all the trunks in the chosen level are busy.

When an idle trunk is encountered, the test relay connects a helping relay to the "a" wire of the trunk, to check whether the selector at the other end of the trunk is in its normal position and, if this condition obtains, the said relay stops the brush carriage and completes a circuit for making the trunk busy and preventing two first group selectors from seizing the same trunk.

*Selection Beyond.* When a trunk has been taken into exclusive engagement, the sequence switch advances to a position where the "a" and "b" wires of the trunk are extended to the register in order that the latter may control the selectors beyond to obtain the required connection.

*Discriminating Signals Received from Register.* When the register has finished selecting beyond, it signals to the sequence switch to advance to one of three positions, depending upon whether the call is ordinary, special service or for a toll operator. This discrimination is effected by the condition of the trunk "a" and "b" reversed in conjunction with the absence or presence of a signal from the register.

*Ordinary Calls with Single Metering.* For ordinary calls, the sequence switch stops in a ringing and busy position where it waits until the called party replies or busy tone is received.

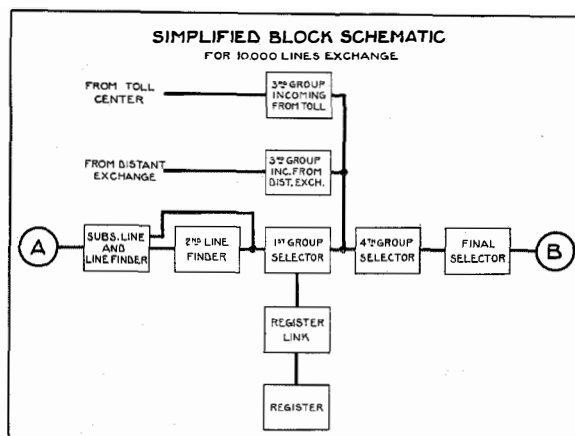

Figure 1—Simplified Block Schematic for 10,000 Lines Exchange.

When the called party replies, one metering signal or one of two groups of multiple metering signals may be sent (if required) via the line finder to actuate the calling subscriber's message register. A single metering is effected while the sequence switch is advancing to a talking position.

*Multiple Metering.* For multiple metering, the sequence switch stops in an intermediate position and signals for a multiple metering circuit which, when attached, energises the subscriber's message register the requisite number of times, and the sequence switch then moves to the talking position and releases the multiple metering circuit. Discrimination between the three different meterings (for three zones) was previously signalled from the register, and the discrimination between the two groups of multiple meterings is signalled from the first group selector circuit to the multiple metering circuit. Single metering may be suppressed, say, for an inner telephone zone for which calls are not to be metered, and the two groups of multiple meterings used for the calls for two outer zones.

*Talking and Release.* When the sequence switch reaches the talking position, the calling and called subscribers' lines are connected together over condensers, and transmitter feeding battery is supplied. The caller may release the connection, and a timed back release is provided for the called subscriber whereby, if he is the first to replace the receiver on the switchhook, his supervisory relay will signal the false call circuit, which, after an interval, will release the



connection and deal with the calling line as a false call, provided the caller has not cleared in the meantime.

*Special Service Calls.* For special service calls, the sequence switch stops in a special talking position, and the metering as described in the preceding paragraphs does not function. For calls to desks (for information, etc.), where switchhook supervision is not required from the caller, the release of the connection is under the control of the caller. For calls to operators' positions (for suburban service, etc.), where switching may occur, the release of the connection is under the control of the caller until the operator answers, after which it passes to her; switchhook supervision is also given. Where required, provision is made on the third wire for the operator to energise the calling subscriber's message register as many times as may be necessary.

*Toll Calls and Outgoing Calls to Rural.* For calls to a toll operator, the sequence switch stops in a metallic through position and extends the "a" and "b" wires of the calling line direct to the trunk. The connection is held from the trunk circuit to the toll operator, and the release of the connection is under the control of the caller until the operator answers.

The subscriber receives transmitter current from a repeating coil bridge in the toll trunk circuit, and low resistance supervisory relays are used with ballast lamps controlling the feed to the subscriber's transmitter. The toll operator receives complete supervisory signals and may re-ring the subscriber.

The rapid development of no delay toll service makes this arrangement particularly valuable, because it increases the range of the subscriber's transmitter and permits normal gauge wire to be used for long subscriber lines, without exceeding

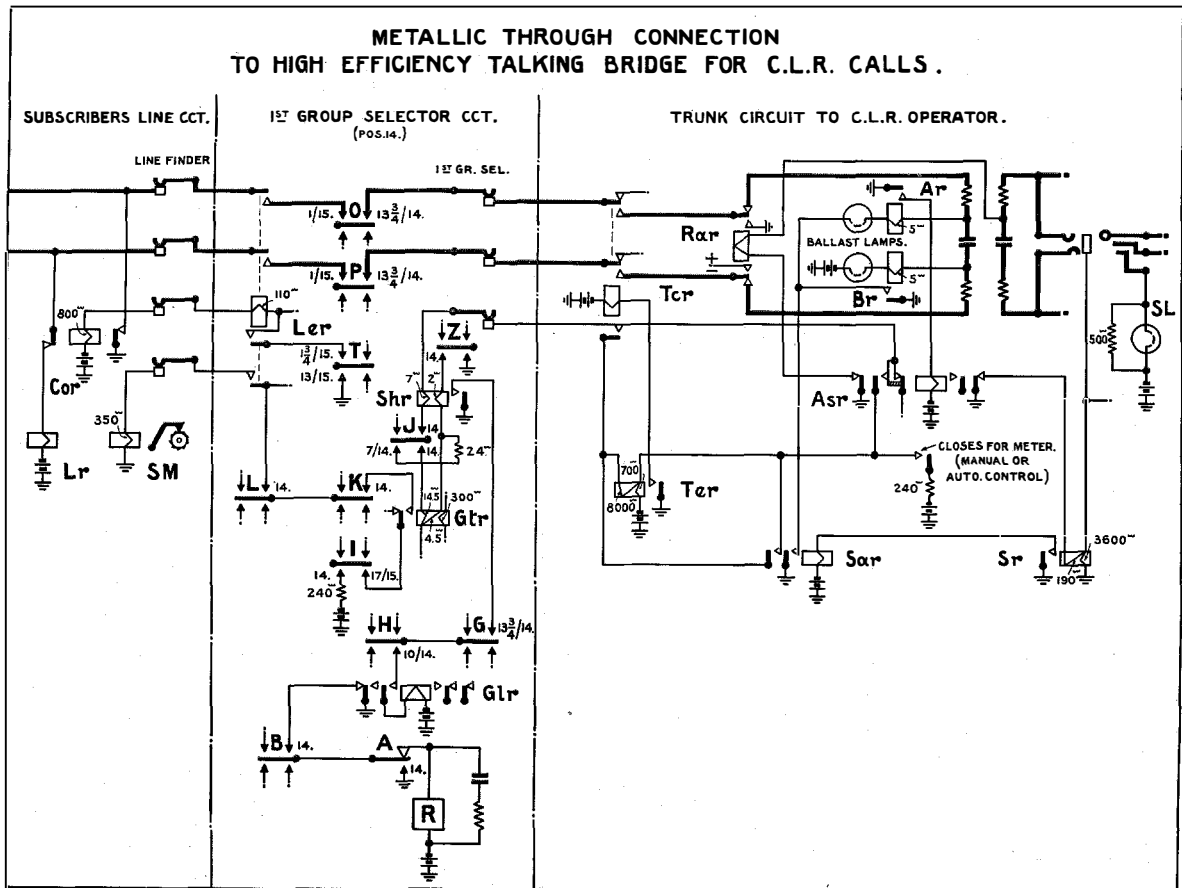

Figure 2—Metallic Through Connection to High Efficiency Talking Bridge for C.L.R. Calls.

the permissible transmission loss. It also avoids delay, the operator being able to ring back the calling subscriber or P.B.X. operator.

Figure 2 shows the subscriber's line connected metallicly through the first group selector to the toll board trunk. It also shows the method of holding, transmitting supervisory signals and metering over the third wire. For outgoing connections to rural networks or to other types of systems where further dialling is required after the release of the local register, the metallic through connection is also valuable.

It enables the subscriber's dial impulses to be properly received and repeated in the trunk circuit to the rural network, thereby simplifying the local automatic equipment. This advantage is more apparent where time and zone metering is provided on rural calls, because in most cases these do not exceed 15% of the total, and it is clearly advantageous to locate the special equip-

ment required apart from the local equipment.

*Repeated Metering.* Provision is made for the third wire of a chosen trunk to control repeated metering when the sequence switch is in the ordinary talking position, the metallic through position or the special service talking position.

*False Call.* Means are provided whereby, in the case of a false call, the register signals the sequence switch to advance to a false call position, and signals a false call and malicious call finder circuit to attend to the call.

*Malicious Call.* Means are provided whereby, in the case of a malicious call, the called party (or an observation operator) may signal the sequence switch to advance to a malicious call position and thereby signal a false call and malicious call finder circuit to attend to the call. The release of the connection between the calling and called lines is then controlled only by the called party (or operator).

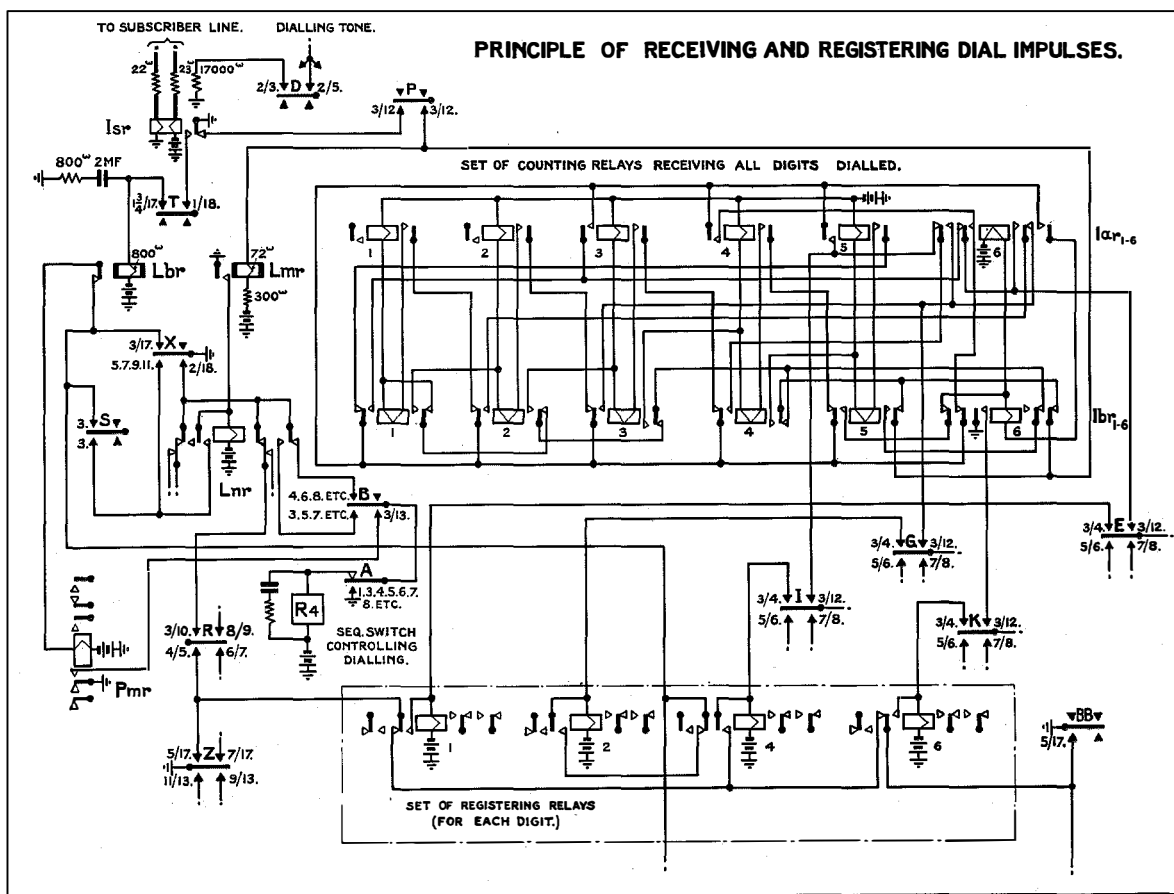

Figure 3—Principle of Receiving and Registering Dial Impulses.

*Sub-normal.* After the circuit has been released from any class of call, the sequence switch advances to a sub-normal position. When the next call arrives, a delay is thereby introduced which ensures that a caller will generally obtain a different first group selector circuit for a second call, thus preventing a subscriber from repeatedly seizing a faulty circuit.

*Restricted Service.* Provision is made for signalling restricted service from a subscriber's line circuit to the register; this signal may also be given from the first group selector circuit when restricted service subscribers are grouped.

*Coin Collectors.* Provision is made for signalling coin collector service to the register when a separate group of first group selector circuits is used for coin collectors.

**Register Circuit**

The register circuit of the 7-A.2 System differs

from its predecessors mainly in the design of the "insteping" or digit receiving circuit. Only one set of dial impulse counting relays receiving all digits is provided. In the interval elapsing between each digit, a record of the number of impulses received is transferred to a set of four storing relays, and the counting relays are released in readiness to receive the following digit (see Figure 3).

The well known Rotary System method of reverteive impulse control of the selectors is retained, and a second set of counting relays is provided for this purpose. A jumpering field is provided between the digit storing relays and the reverteive impulse counting relays, thus making the register circuit practically universal in its application. By suitable jumpering, 4, 5 or 6 digit dialling and, where required, mixed numbering can be arranged. The routing of any class of call can be made independent of the cor-

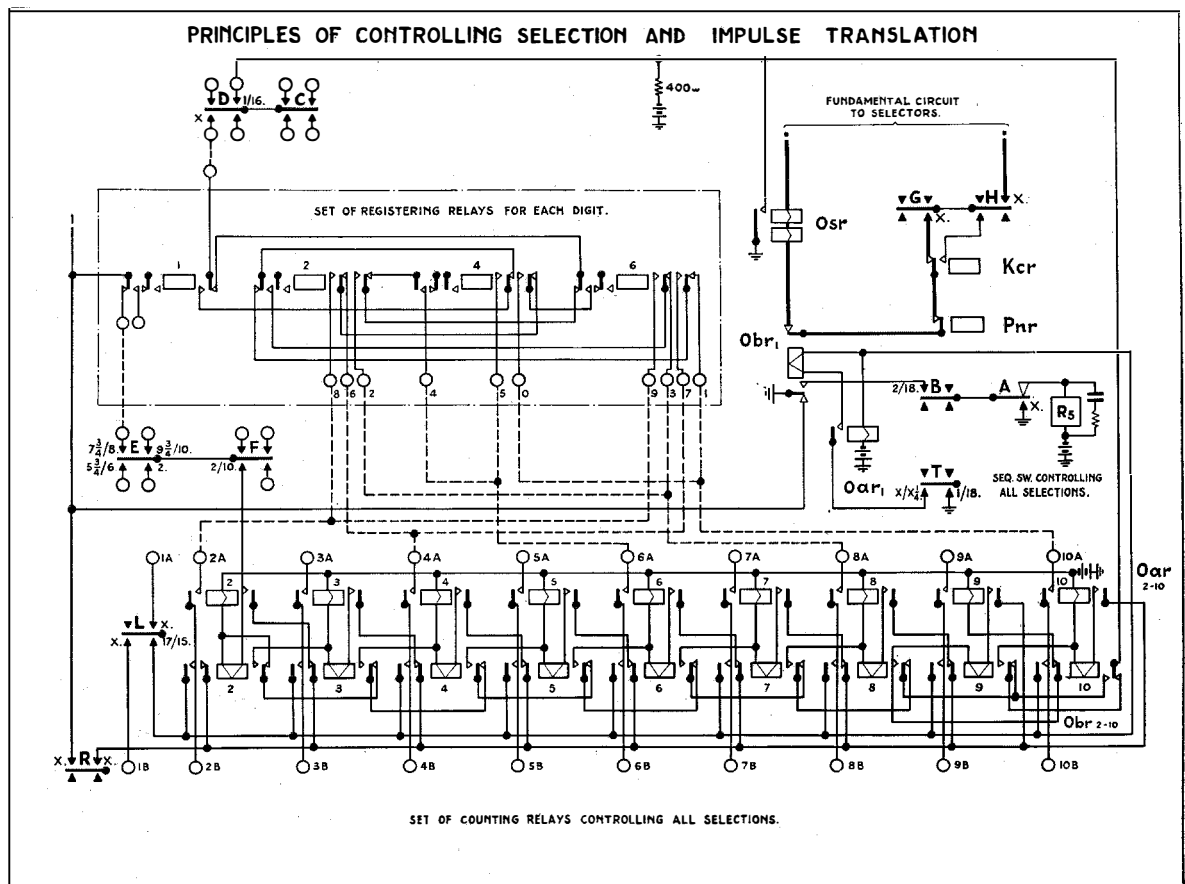

Figure 4—Principles of Controlling Selection and Impulse Translation.

responding dialled digits and, moreover, can be easily changed to suit changing traffic conditions. A translator switch can be introduced between the storing relays and outstepping counting relays, but the flexibility of the jumpering field makes the translator unnecessary except for very large networks.

### Working Limits

#### SUBSCRIBER'S LINE:

Dial Speed	Maximum External Loop Resistance Including Telephone	Minimum Insulation Resistance	Extension Set in Parallel
10 impulses per sec. (min., 7; max., 14)	1,400 ohms	10,000 ohms	Yes
20 impulses per sec. (min., 7; max., 24)	1,000 ohms	10,000 ohms	No

#### TRUNK:

Maximum External Loop Resistance	Minimum Insulation Resistance	When Register is Outstepping, the External Loop Resistance shall be Compensated to:
1,400 ohms	20,000 ohms	1,200 ohms
2,600 ohms	50,000 ohms	2,400 ohms

*Receiving Subscriber's Dial Impulses.* When the register has become attached to a first group selector circuit, the instepping relay is prepared for receiving the first digit, and dialling tone is then connected to the calling line.

The caller dials the first digit and the instepping relay, in conjunction with the train of impulse counting relays, registers the number of impulses received (1 to 10) on the first group of storing relays. The latter are energised in one of a number of combinations, and thereby prepare a circuit for one of ten marking wires associated with the first digit. The storing relays are designated 1, 2, 4 and 6, and they are arranged so that the identity of the stored digit may be ascertained visually by adding the designation numbers of the energised relays.

The second and successive digits are in a

similar manner registered on groups of storing relays, which are connected in turn to the impulse counting train of relays by the sequence switch.

*Selection.* The ten marking wires of each group of storing relays are connected to a field of terminals which are jumpered to other terminals associated with the outstepping relay counting train and controlling relays.

The groups of storing relays each prepare a path via a chosen marking wire. These paths are connected in turn by the sequence switch to the outstepping counting train or associated relays, and serve to control the selection. A translator may be employed when required.

The routing of a call may be independent of the numbering scheme because the instepping and outstepping are associated as required. Additional selections can thereby be introduced for tandem trunking or alternative trunking schemes.

During selection, an outstepping relay responds to reverte impulses from the commutator of a group or final selector, and energises in turn the pairs of relays of an outstepping counting train.

When the required number of reverte impulses have been received, an additional pair of counting relays functions to open the fundamental circuit, and thereby stop the selector at the required point, and also advance the sequence switch of the register for the next selection.

*Outstepping Counting Relays.* The nine pairs of outstepping counting relays are arranged so that the second relay of each pair releases the preceding pair. The second relay of the ninth pair is arranged, when energised, to reconnect the impulse circuit to the first pair (see Figure 4).

When ten additional reverte impulses have to be counted in connection with the units selection of an odd hundred, the six pairs of impulse counting relays count the first ten reverte impulses, and then the outstepping pairs of counting relays function to count the balance as previously described.

The sequence switch controls the sequence of selections, and a maximum of seven selections may be employed. When a selection has been completed, the sequence switch advances to the

next selecting position, and selection proceeds when the referring digit or digits have been received from the caller, and an idle trunk has also been found and connection established to the selector ahead.

*Special Service Calls.* For special service calls, mixed one, two or three digits may be employed. The number of selections may be one, two, three or four, and independent of the digit or digits dialled.

*Restricted Service.* For restricting the service of a subscriber, provision is made to receive a signal from his line circuit via the first group selector and register link circuits. When restricted subscribers are grouped, the signal may be received from the associated first group selector circuits.

*Coin Collectors.* For the purpose of routing certain calls from coin collectors to special trunks to toll or suburban, for coin control, etc., provision is made to receive a signal from the associated first group selector circuits.

*False Calls.* In the case of a so-called false call (no dial impulses received), the register will, after an interval of about 30 seconds, advance the sequence switch of the first group selector to a false call position and then release the register link and itself.

*Incomplete Dialling.* If a caller only partially dials a wanted number, the register will, after an interval of about thirty seconds, release the connection. The call, if it persists, will then reappear and the caller will receive dialling tone.

*Holdover Feature.* The well known aid to fault finding, namely, the holdover feature, is retained. It is so named because, in the event of a fault occurring, the train of selectors is prevented from releasing and an alarm is given to the maintenance force. The holdover is indicated by the register circuit, and in the event of the selection at any stage not progressing or being delayed beyond thirty seconds, the calling line will be released and leave the register connected to the register link and first group selector, etc. This condition is signalled at the register by a fault lamp in conjunction with the instepping sequence switch standing in the "await end of selection" position. A key is provided for releasing a holdover, and it may also

be employed to put the holdover circuit out of service.

*Non-existing Numbers.* If a caller dials a non-existing number, the call is extended to an assigned dead line and the caller receives dead line tone.

*Two-party Revertive Ringing.* When any two assigned digits are dialled, ringing current is connected to the calling line for a short time, for revertive calls on party lines (two-party).

*Multiple Metering.* For multiple metering, means are provided for two signals to be sent to the first group selector circuit, thus catering for three zones, one with single metering and the other two with multiple metering.

*Call Indicator.* Calls for a trunk associated with a call indicator may be arranged to cancel the hunting (register waits until a free trunk is found) after a particular selection. In case of a fault causing incomplete display of the call indicator lamps, the operator may release the automatic exchange register, and may obtain direct connection with the calling party and take the wanted number verbally.

*Rural Calls.* Calls for rural exchanges are arranged, when necessary, to cancel the pairing and hunting.

Some, or all, of the dialled digits may also be repeated to the rural exchange for selecting purposes. Mixed five and six digit calls can be dealt with; five digits for 7-A.2 exchanges and six digits for rural exchanges.

*Calls to Step-by-step Exchanges.* Calls for step-by-step exchanges are arranged to cancel the pairing and hunting, and also the waiting position between the tens and units selections.

*Traffic Metering.* Traffic metering circuits are provided for counting the:

- |                                     |   |  |
|-------------------------------------|---|--|
| (1) number of line seizures         | } | Grand total                                  |
| (2) totally dialled effective calls |   |  |
| (3) totally dialled effective calls | } | For each group of 10,000 subscribers' lines. |
| (4) totally dialled effective calls |   |  |
| (5) totally dialled effective calls | } | For each group of 1,000 subscribers' lines.  |
|                                     |   |  |

### *Intermediate Selectors*

The second and third group selectors, both local and incoming, require no description. They consist of a regular selector, sequence switch and a number of relays, depending on the type of circuit.

### **Fourth Group Selector**

The fourth group selector, in conjunction with a sequence switch and four relays (one additional for toll or manual service) and under the control of a register circuit, selects one of ten levels of arc terminals and hunts for a free trunk in that level leading to a final selector.

Three distinctive signals are received from the final selector circuit, indicating whether the wanted line is free, busy or dead.

If the final selector signals line free, ringing tone is connected towards the calling party, and uninterrupted ringing current towards the wanted line. After a timed interval the uninterrupted ringing is replaced by interrupted ringing. When the wanted party answers, either during a silent or ringing period, the ringing circuits are replaced by a metallic talking circuit.

If the final selector signals line busy, busy tone is connected towards the calling party.

If the final selector signals line dead, dead line tone is connected towards the calling party.

On a call from a toll or manual board the automatic ringing is disabled, and on the receipt of the signal from the final selector that the wanted line is free, a metallic through connection is established. Should the final signal line busy, a busy flash, in addition to busy tone, is sent back to the operator.

### **Final Selector**

The final selector, in conjunction with a sequence switch and three relays and under the control of a register circuit, selects one of ten levels of arc terminals and a set of terminals within that level giving access to the required line.

*Single Line Found Free.* If the selected line is a single line and is free, the connection is established and a signal is sent to the fourth group selector circuit, indicating that ringing current should be connected towards the called line and ringing tone to the calling party.

*Single Line Found Busy.* If the selected line is a single line and is busy, the connection is not established, and a signal is sent to the fourth group selector circuit, indicating that busy tone should be connected to the calling party.

*Dead Line.* If the selected line is a dead line

a signal is sent to the fourth group selector indicating that dead line tone should be connected to the calling party.

*P.B.X. Lines.* If the selected line is the first line of a group of P.B.X. lines and is free, the connection is established and a signal is sent to the fourth group selector indicating that ringing should be connected towards the called line and ringing tone to the calling line.

If the selected line is the first line of a group of P.B.X. lines and is busy, the final selector commences to hunt over the remaining lines of the group, and will stop on the first free line and will then signal free. If all the lines in the group are busy, the final selector will stop on the last line of the group and signal busy.

For small groups of P.B.X. lines (say two lines per group), where a caller, on finding the group busy, may then proceed to dial the last line, means are provided whereby the last line of such a group will test as a single line until a final selector is actually P.B.X. hunting in that group. This ensures that a caller for such a busy last line will generally get busy tone and not a wrong connection.

*Waiting for Called Subscriber to Release.* If, after a caller has replaced his receiver on the switchhook, the called party does not also release, the final selector remains held by the loop of the called party for a timed interval, after which the connection is released and the loop of the called party becomes a false call.

The final selector is used for combined local and toll service and Wire Chief test.

### **Routine Testing Facilities**

*Selector and Multiple Testing.* Any selector may be used as a routine test access switch for testing the selector multiple or the circuits beyond. The access switches may be changed at intervals and the selector multiples thus periodically tested from each bay and, if necessary, from each switch.

As part of each sequence switch, there is provided a simple key which, when operated with a wooden plug in the busy jack, will cause the sequence switch to move to a chosen position where, for maintenance purposes, the selector trip spindle may be tested and the brush carriage rotated with the brushes in a disconnected con-

dition. This feature is also utilised in connection with the routing test when using a group selector as an access switch to test the selector multiple or circuits beyond; the clutch magnets of the trip spindle and brush carriage, and the "a," "b" and "c" brushes, are extended to a routine test circuit by means of a test clip, and the selector is thereby stepped from trunk to trunk. When all the selectors which can be reached from one access switch have been tested, the routine test circuit is automatically switched to a second access switch, and this operation is continued until all selectors of a given type have been tested. The routine testing scheme is planned to permit simultaneous testing of different kinds of circuits, e.g., first group, second group, third group, fourth group and final selectors, each having their own routine test circuits. It is also possible to test the different types of selectors in succession, each test circuit having completed its work automatically starting the next. With this method of testing, a printer shows the condition of each selector tested, i.e., correct, faulty or engaged. In this way the exchange maintenance officer can very rapidly check the condition of the equipment from line finder to final selector.

For the testing of the first group selector circuits and the register circuits, line finder type

access switches are mounted on the register link bays. The complete multiple of register circuits found on the register finder bays makes it easy to obtain access to the register circuits, and likewise the link finder multiple gives convenient access to the first group selectors.

### *Satellites*

As part of the 7-A.2 System, a new type of satellite has been designed. The two hundred point type line finder is used as a combined line finder and final selector associated with a two-wire, two-way trunk to the parent exchange.

Local calls are completed over local link circuits, which do not occupy the parent exchange trunk.

### *Auxiliary Circuits*

Apart from the principal circuits described briefly above, there are a number of auxiliary circuits. Space does not permit of more than mention of their existence.

There is the toll first group selector for inward toll connections; there are circuits for Centralised Wire Chief Testing and Centralised Service Observation. There are the miscellaneous circuits, such as dead line, dead level, various tone circuits and a complete series of routine test circuits.

## ERRATUM

*Electrical Communication*, Vol. XII, No. 1, July, 1933, Page 5, "The Production and Utilization of Micro-Rays."

For the third and fourth sentences in the first paragraph under caption "3. Case of Plane Electrodes," the following should be substituted:

Let us call  $r_a$  the radius of the cathode,  $r_o$  the radius of the oscillating electrode and  $r$  any radius between  $r_a$  and  $r_o$ ,  $r$ ,  $r_a$  and  $r_o$  being, of course, infinite. Although the value of  $r_a$  plays no part in the plane case, it is introduced to maintain the same form as in the cylindrical electrode case.

# INTERFERENCE CONQUERED by KB

K. B. announce the almost complete suppression of "man-made static"—interference caused by electrical machinery, such as motors, trams, lifts, sweepers, illuminated signs, etc. This is accomplished by the K. B. "Rejectostat" System. Provided the aerial is placed outside the field of interference, all channels by which electrical interference enters a receiver are closed. In addition to other valuable and interesting features, the new K. B. models possess sensitivity, selectivity and quality of reproduction reaching a new high level. K. B. lead in cabinet design, too.

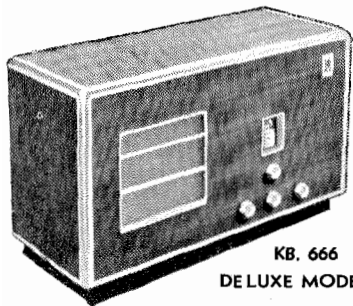

KB. 666  
DELUXE MODEL

*K. B. 666 6-Valve A.C. Super-Het Receiver* (including rectifier) with Moving Coil Speaker. Automatic Tone Compensation and Automatic Volume Control. Manual Tone and Volume Controls. Output 3 watts. Can be used for Short Wave reception with converter. Models for 200-250 volts or 100-130 volts, 40-60 cycles. Two cabinets: Standard—Walnut and Macassar Ebony; De Luxe—Walnut with Chromium-plated metal edges and fittings. Stand furnished for either model.

*K. B. 444 4-Valve A.C. Super-Het Receiver* (including rectifier) with Moving Coil Speaker. 2 H.F. Pentodes and Output Pentode. Output  $2\frac{1}{2}$  watts. Very sensitive and selective. Single knob tuning; calibrated scale. Can be used for Short-Wave reception with converter. Walnut and Macassar Ebony cabinet. Models for 200-250 volts or 100-130 volts, 40-60 cycles.

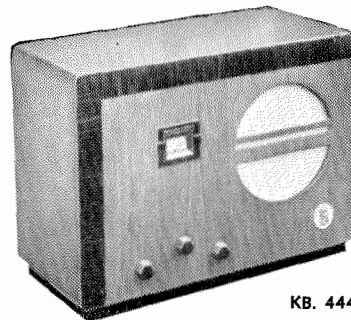

KB. 444

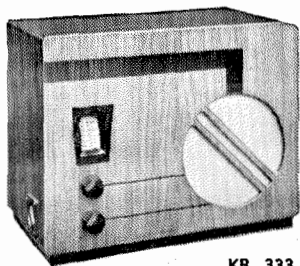

KB. 333

*K. B. 333 3-Valve Band-Pass Battery-operated Receiver* with P. M. Moving Coil Speaker. Band-pass tuning gives remarkable selectivity with good quality reproduction. Single knob tuning; calibrated scale. Tone filter. Walnut and Macassar Ebony cabinet.

**KOLSTER-BRANDES LTD.,**  
CRAY WORKS, SIDCUP, KENT, ENGLAND



★ ★ **KB - THE NEW RADIO** ★ ★



# Micromesh

TRADE MARK

## THE MODERN VALVE

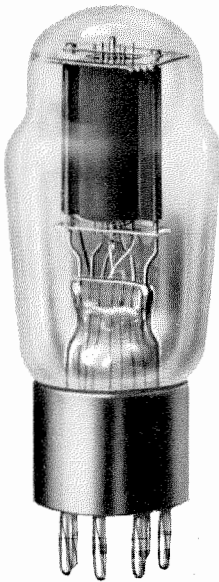

**TYPE 7A.2 VALVE**

The MICROMESH type 7A.2 is an indirectly heated power pentode capable of giving an undistorted power output in excess of 3.0 watts, with a grid output of 10 volts R.M.S.

This output is sufficient to operate large moving coil speakers at considerable volume.

- Heater Voltage..... 4.0 volts  $\pm$  5%
- Heater Current..... 1.2 amps.
- Max. Anode Voltage.... 250 volts
- Max. Screen Voltage.... 250 volts
- Max. Anode Current.... 40 mA
- Normal Grid Bias. .... 17.0 volts
- Mutual Conductance..... 3.2 mA per volt
- Optimum Load..... 8,000 ohms (approx.)
- Undistorted Power Output..... 3.0 watts

- Heater Voltage..... 4.0 volts  $\pm$  5%
- Heater Current..... 1.0 amp.
- Max. Anode Voltage.... 250 volts
- Max. Screen Voltage.... 100 volts
- \*Amplification Factor... 1,500
- \*Mutual Conductance... 4.0 mA, per volt
- \*Impedance..... 375,000 ohms
- \* Measured at anode volts 200, screen volts 100, grid volts zero.

*Fully detailed lists and prices upon application.*

The MICROMESH 8A.1 is an indirectly heated radio frequency pentode valve.

Although this valve may be used as a radio frequency amplifier, it should be only used as such where some form of pre-H.F. volume control is employed.

In certain cases it will be found extremely useful where a valve with a short grid bias is required for use in automatic volume control circuits.

It is extremely useful as first or second detector, or as detector oscillator in receivers of the super-heterodyne class.

The voltage of the heater pins should be 4 volts  $\pm$  5%.

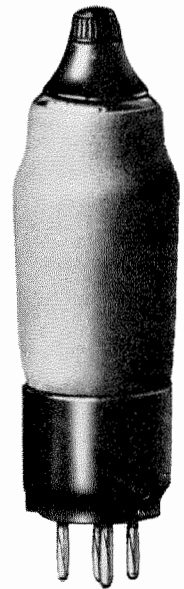

**TYPE 8A.1 VALVE**

# Standard Telephones

(RADIO MERCHANDISE DEPT.) ST. CHAD'S PLACE, 364,

**Micromesh**  
TRADE MARK  
**THE MODERN VALVE**

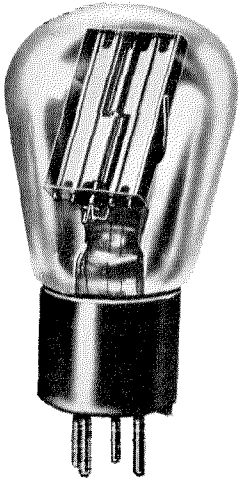

**TYPE R.1 VALVE**

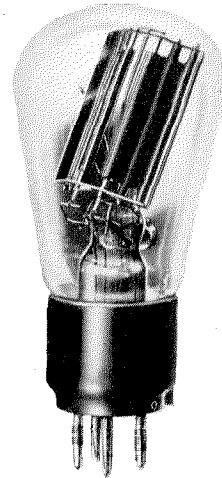

**TYPE R.2 VALVE**

	R.1	R.2	R.3
Heater Volts.....	4.0	4.0	4.0
Heater Amps.....	1.0	2.25	2.25
Max. Anode Voltage R.M.S.....	250-0-250	350-0-350	500-0-500
Max. Rectified Current mA.....	60	120	120

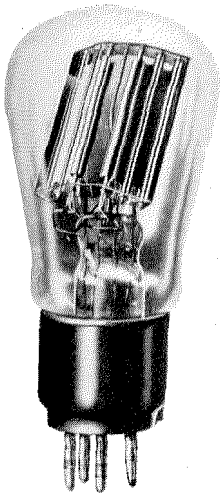

**TYPE R.3 VALVE**

These MICROMESH rectifiers are all of the indirectly heated type, designed to give a long and useful life. Owing to the fact that these valves heat up at the same speed as the receiving valves, no undue voltage strain is thrown on the smoothing circuits, as is experienced with other types of rectification.

Full advantage is taken of the unique MICROMESH construction, which allows of adequate cooling of the anodes, resulting in an extremely long life. In addition, the close spacing of the electrodes reduces the impedance to a small value, resulting in a somewhat higher D.C. output than is possible with other types of rectifiers.

*Fully detailed lists and prices upon application.*

**and Cables Limited**

GRAY'S INN ROAD, LONDON, W.C.1. 'PHONE: TERMINUS 6255

## INTERNATIONAL TELEPHONE AND TELEGRAPH CORPORATION

### BOARD OF DIRECTORS

<p>ARTHUR M. ANDERSON J. P. Morgan &amp; Co.</p> <p>HERNAND BEHN, President</p> <p>SOSTHENES BEHN, Chairman</p> <p>F. WILDER BELLAMY Dominick &amp; Dominick</p> <p>EDWARD J. BERWIND Chairman, Berwind-White Coal Mining Company</p> <p>EDWIN F. CHINLUND, Vice-President and Comptroller</p> <p>PHILIP K. CONDUCT Executive Vice-President, International Standard Electric Corporation</p> <p>JOHN W. CUTLER Edward B. Smith &amp; Co.</p> <p>R. FULTON CUTTING Financier</p> <p>GEORGE H. GARDINER Davis Polk Wardwell Gardiner &amp; Reed</p> <p>GEORGE S. GIBBS President, Postal Telegraph and Cable Corporation</p> <p>A. H. GRISWOLD Executive Vice-President, Postal Telegraph and Cable Corporation</p>	<p>ALLEN G. HOYT Vice-President, The National City Bank of New York</p> <p>RUSSELL C. LEFFINGWELL J. P. Morgan &amp; Co.</p> <p>CLARENCE H. MACKAY Chairman of the Board, Postal Telegraph and Cable Corporation</p> <p>JOHN L. MERRILL President, All America Cables, Incorporated</p> <p>WALTER E. OGILVIE President, Havana Terminal Railroad Company</p> <p>HENRY B. ORDE President, Shanghai Telephone Company</p> <p>BRADLEY W. PALMER Chairman of the Executive Committee, United Fruit Company, Boston</p> <p>GEORGE E. PINGREE President, International Standard Electric Corporation</p> <p>WOLCOTT H. PITKIN, Vice-President and General Attorney</p> <p>LEWIS J. PROCTOR, Vice-President</p> <p>LANSING P. REED Davis Polk Wardwell Gardiner &amp; Reed</p>
--	---

GEORGE H. GARDINER  
General Counsel

### OFFICERS

<i>Chairman</i>	<i>President</i>	
SOSTHENES BEHN	HERNAND BEHN	
	<i>Vice-Presidents</i>	
LEWIS J. PROCTOR GEORGE E. PINGREE PHILIP K. CONDUCT	JOHN L. MERRILL FRANK W. PHELAN WILLIAM F. REPP A. H. GRISWOLD	FRANK C. PAGE LOGAN N. ROCK GEORGE S. GIBBS
<i>Vice-President and General Attorney</i>	<i>Vice-President and General Technical Director</i>	<i>Vice-President and Comptroller</i>
WOLCOTT H. PITKIN	GERALD DEARIN	EDWIN F. CHINLUND
<i>Secretary</i>		<i>Treasurer</i>
SAMUEL G. ORDWAY		JOSEPH A. REDEGELD

THE International Telephone and Telegraph Corporation was organized to cooperate and assist technically and financially in the general development of electrical communications in a broad international sense, and, with respect to the organization and development of national communications systems, it is the purpose of the International Telephone and Telegraph Corporation to develop truly national systems operated by the nationals of each country in which the International Corporation is or may become interested. The International Corporation was not organized with the desire of imposing American practices in its foreign activities. There appeared

to be a fruitful field of service to be rendered in bringing together under one general organization electrical communications systems, and the extension, by the International Corporation to the associated companies, of the technical and financial facilities and direction that might be needed for their intensive and efficient development. The best American practices have been suggested but never imposed. On the contrary, the International Corporation has always been ready and quick to adjust American practices to local conditions and to adopt such local practices as were conducive to the successful development of the various entities.

---

---

## *Licensee Companies*

- BELL TELEPHONE MANUFACTURING COMPANY.....*Antwerp, Belgium*  
*Branches: Brussels.*
- BELL TELEPHONE MANUFACTURING COMPANY.....*Berne, Switzerland*
- BELL TELEPHONE MANUFACTURING COMPANY.....*The Hague, Holland*
- STANDARD ELECTRIC DOMS A SPOLECNOST.....*Prague, Czechoslovakia*  
*Branch: Bratislava.*
- CHINA ELECTRIC COMPANY, LIMITED.....*Shanghai, China*  
*Branches: Canton, Hankow, Harbin, Hongkong, Peiping, Tientsin.*
- COMPAÑÍA STANDARD ELECTRIC ARGENTINA.....*Buenos Aires, Argentina*
- INTERNATIONAL STANDARD ELECTRIC CORPORATION, *Branch Office,*  
*Rio de Janeiro, Brazil*
- LE MATERIEL TÉLÉPHONIQUE.....*Paris, France*  
*Rabat, Morocco*
- NIPPON DENKI KABUSHIKI KAISHA.....*Tokyo, Japan*  
*Branches: Osaka, Dairen, Taihoku.*
- FERDINAND SCHUCHHARDT, BERLINER FERNSPRECH-UND TELEGRAPHENWERK  
AKTIENGESELLSCHAFT.....*Berlin, Germany*
- STANDARD ELECTRIC AKTIESELSKAB.....*Copenhagen, Denmark*
- STANDARD ELECTRIC AKTIESELSKAP.....*Oslo, Norway*
- AKTIESELSKABET SKANDINAVISKE KABEL- OG GUMMIFABRIKER.....*Oslo, Norway*
- STANDARD ELECTRIC COMPANY W POLSCE SP. Z. O. O.....*Warsaw, Poland*
- STANDARD ELECTRICA ROMANA S/A.....*Bucharest, Rumania*
- STANDARD ELÉCTRICA, S. A.....*Madrid, Spain*  
*Branches: Barcelona, Santander.*
- STANDARD ELECTRICA, S. A.....*Lisbon, Portugal*
- STANDARD ELETRICA ITALIANA.....*Milan, Italy*  
*Branch: Rome.*
- STANDARD TELEPHONES AND CABLES, LIMITED.....*London, England*  
*Branches: Birmingham, Glasgow, Leeds, Manchester, Dublin, Cairo, Johannes-  
burg, Calcutta, Singapore.*
- STANDARD TELEPHONES AND CABLES (AUSTRALASIA), LIMITED.....*Sydney, Australia*  
*Branches: Melbourne, Wellington.*
- STANDARD VILLAMOSSÁGI RÉSZVÉNY TÁRSASÁG.....*Budapest, Hungary*
- SUMITOMO ELECTRIC WIRE & CABLE WORKS, LIMITED.....*Osaka, Japan*
- ÖSTERREICHISCHE TELEPHON-FABRIK AKTIENGESELLSCHAFT.....*Vienna, Austria*
- VEREINIGTE TELEPHON-UND TELEGRAPHENFABRIKS AKTIEN-GESELLSCHAFT,  
CZEIJA, NISL & CO.....*Vienna, Austria*

---

*Sales Offices and Agencies Throughout the World*

---

---